

# OCR

Oxford Cambridge and RSA

## Friday 15 June 2018 – Afternoon

### AS GCE MATHEMATICS (MEI)

4761/01 Mechanics 1

#### QUESTION PAPER

Candidates answer on the Printed Answer Book.

##### OCR supplied materials:

- Printed Answer Book 4761/01
- MEI Examination Formulae and Tables (MF2)

##### Other materials required:

- Scientific or graphical calculator

**Duration:** 1 hour 30 minutes

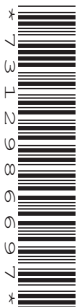

#### INSTRUCTIONS TO CANDIDATES

These instructions are the same on the Printed Answer Book and the Question Paper.

- The Question Paper will be found inside the Printed Answer Book.
- Write your name, centre number and candidate number in the spaces provided on the Printed Answer Book. Please write clearly and in capital letters.
- **Write your answer to each question in the space provided in the Printed Answer Book.** Additional paper may be used if necessary but you must clearly show your candidate number, centre number and question number(s).
- Use black ink. HB pencil may be used for graphs and diagrams only.
- Read each question carefully. Make sure you know what you have to do before starting your answer.
- Answer **all** the questions.
- Do **not** write in the barcodes.
- You are permitted to use a scientific or graphical calculator in this paper.
- Final answers should be given to a degree of accuracy appropriate to the context.
- The acceleration due to gravity is denoted by  $g \text{ ms}^{-2}$ . Unless otherwise instructed, when a numerical value is needed, use  $g = 9.8$ .

#### INFORMATION FOR CANDIDATES

This information is the same on the Printed Answer Book and the Question Paper.

- The number of marks is given in brackets [ ] at the end of each question or part question on the Question Paper.
- You are advised that an answer may receive **no marks** unless you show sufficient detail of the working to indicate that a correct method is being used.
- The total number of marks for this paper is **72**.
- The Printed Answer Book consists of **16** pages. The Question Paper consists of **8** pages. Any blank pages are indicated.

#### INSTRUCTION TO EXAMS OFFICER/INVIGILATOR

- Do not send this Question Paper for marking; it should be retained in the centre or recycled. Please contact OCR Copyright should you wish to re-use this document.

## Section A (36 marks)

- 1 Fig. 1 shows a block of mass 10 kg on a rough horizontal table.

One end of a string is attached to the block. The string passes over a smooth pulley and the other end is attached to a sphere of mass 5 kg which is hanging freely. The string makes an angle of  $30^\circ$  with the vertical. The string is light and inextensible.

The system is in equilibrium.

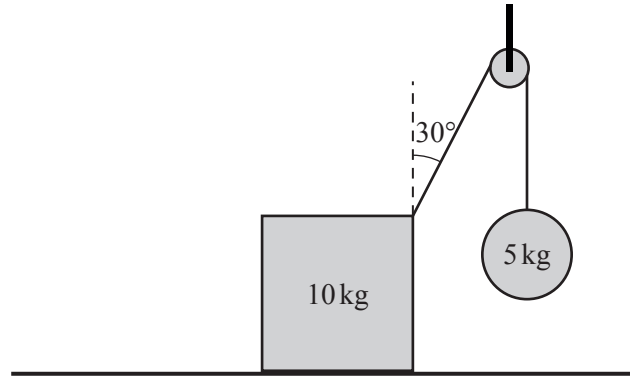

Fig. 1

- (i) Draw a diagram showing all the forces acting on the block. [3]
- (ii) Calculate the normal reaction of the table on the block.  
Calculate also the frictional force acting on the block. [3]
- (iii) Find the magnitude of the resultant of the forces that the table exerts on the block. [2]

2 In this question you should use the standard projectile model with  $g = 9.8 \text{ m s}^{-2}$ .

Fig. 2 illustrates a situation in a cricket match.

A batsman has hit the ball in the air from the point B, 1 metre above the ground at P, towards the boundary at Q. The ground is horizontal and the distance PQ is 70 m. A fielder is standing at Q.

The initial velocity of the ball is  $28 \text{ m s}^{-1}$  at  $30^\circ$  to the horizontal.

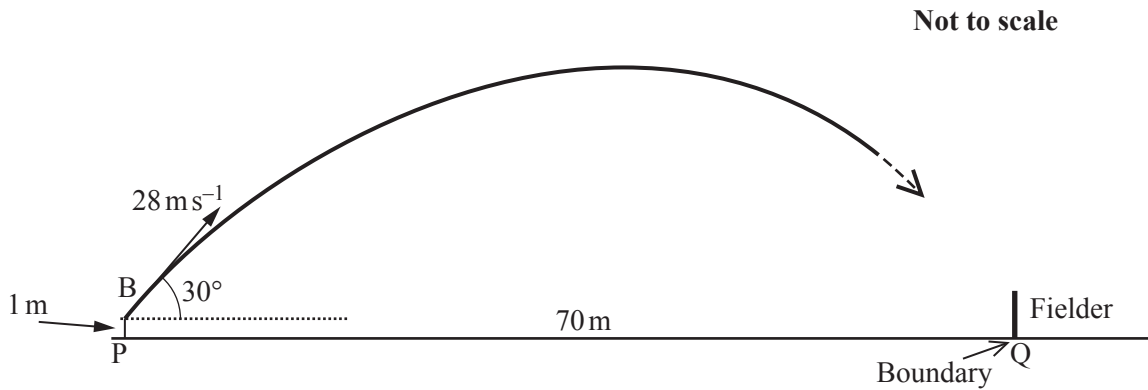

Fig. 2

(i) Find the greatest height of the ball above the ground during its flight. [4]

The height of the ball above the ground when it reaches the boundary at Q is denoted by  $h$  metres.

- If  $h > 2.2$ , the batsman will score 6 runs.
- If  $0 \leq h \leq 2.2$ , the fielder will catch the ball and the batsman will be out.
- If the ball hits the ground before it reaches Q, the fielder will stop it, and the batsman will score 1 run.

(ii) Determine what happens. [4]

3 Fig. 3 illustrates a car towing a trailer. They are connected by a light horizontal tow-bar and are travelling in a straight line along a horizontal road.

- The mass of the car is 1000 kg and the mass of the trailer is 600 kg.
- The resistance to motion is 300 N for the car and 100 N for the trailer.
- The driving force exerted by the car is  $D$  N.

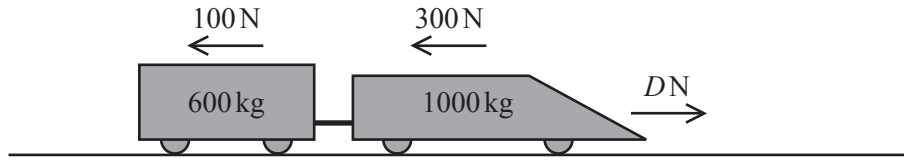

Fig. 3

(i) Initially  $D = 1200$ .

Find the acceleration of the car and the tension in the tow-bar.

[4]

(ii) After some time the driving force is removed so that  $D = 0$ .

Find the new force in the tow-bar, stating whether it is a tension or a thrust.

[4]

- 4 Salome takes a lift from the ground floor of a building vertically upwards to the floor where her office is situated. Her velocity,  $v$ , at time  $t$  is shown in Fig. 4. She stands still in the lift.

Salome's mass is 50 kg.

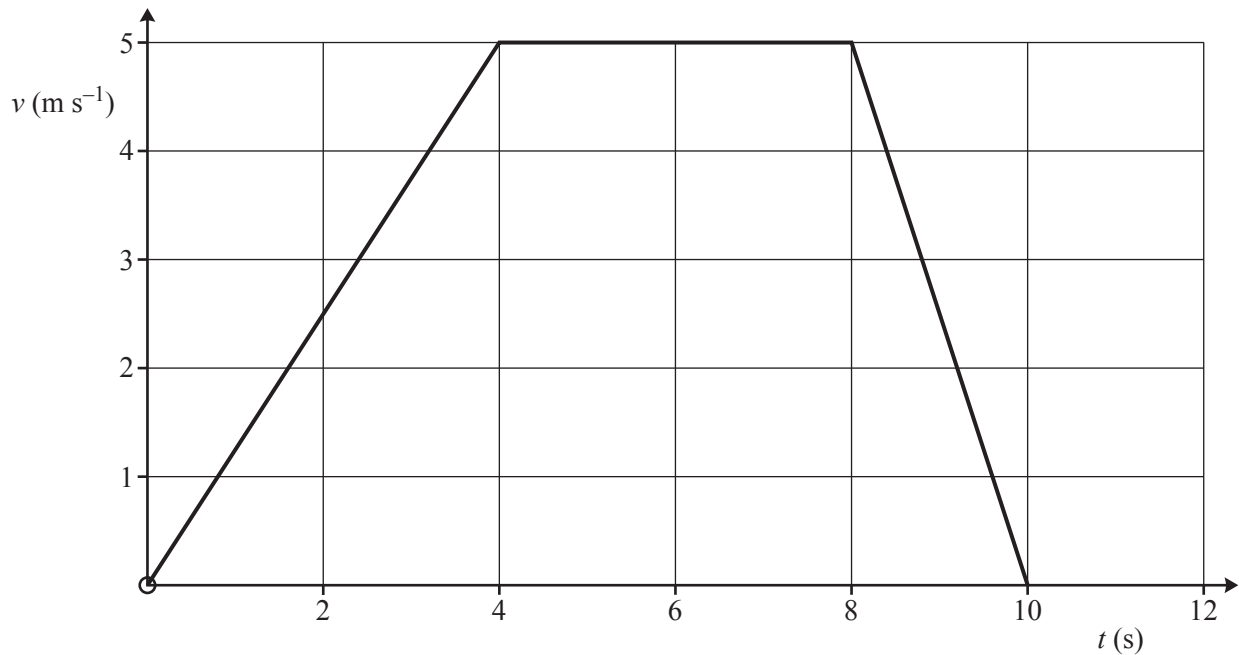

Fig. 4

- (i) Find Salome's acceleration in each of the three phases of her motion. [2]
- (ii) Find the greatest force that the floor of the lift exerts on Salome. [2]
- 5 Alice is driving along a straight narrow country road when she sees that a tree has fallen across the road in front of her. She applies the car's brakes with ever increasing firmness as she approaches the tree.
- The car's initial speed is  $21 \text{ m s}^{-1}$ .
  - The tree is 75 m from the front of Alice's car when she first applies the brakes.
  - The car's acceleration,  $a \text{ m s}^{-2}$ , is given by  $a = -2 - \frac{1}{2}t$  where  $t$  s is the time since Alice first applies the brakes.

Does Alice's car hit the tree?

[8]

## Section B (36 marks)

- 6 Two beetles, A and B, are on a large patio which is modelled as a flat horizontal surface.

Cartesian axes are defined relative to an origin near the middle of the patio; the direction of the  $x$ -axis is East and the direction of the  $y$ -axis is North.

The unit vectors  $\begin{pmatrix} 1 \\ 0 \end{pmatrix}$  and  $\begin{pmatrix} 0 \\ 1 \end{pmatrix}$  are in the  $x$ - and  $y$ - directions.

The unit for distance is 1 metre. Time,  $t$ , is measured in seconds and  $0 \leq t \leq 5$ .

The position vector,  $\mathbf{r}_A$  m, of beetle A at time  $t$  is given by  $\mathbf{r}_A = \begin{pmatrix} t-1 \\ t^2-2 \end{pmatrix}$ .

- (i) Write down A's velocity and acceleration at time  $t$ . [3]

Beetle B is initially at the point  $(-1, 10)$  and is initially moving with velocity  $\begin{pmatrix} 1 \\ -4 \end{pmatrix} \text{ m s}^{-1}$ . It has constant acceleration  $\begin{pmatrix} 0 \\ 2 \end{pmatrix} \text{ m s}^{-2}$ .

- (ii) Find the velocity and position vector of beetle B at time  $t$ . [4]

- (iii) Show that the two beetles meet once and give the coordinates of the place where this happens. [4]

- (iv) Show that the directions of travel of the two beetles are never parallel. [4]

- (v) Prove that there is one, and only one, time at which the speeds of the two beetles are the same. Find the speed at that time. [3]

- 7 This question is about a place where there is a steep cliff with flat horizontal ground at the bottom of it. A railway line runs along this flat ground. The railway line is parallel to the bottom of the cliff and at a distance of 100 m from it.

Hari is surveying the situation to see if stones falling down the cliff present any danger to the trains. Fig. 7 is his illustration of the place. He uses it for three models of a stone sliding down from the top of the cliff and across the flat horizontal ground towards the railway.

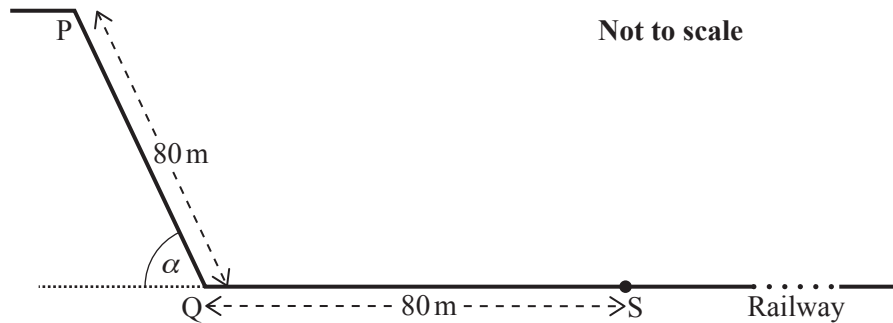

Fig. 7

He makes the following assumptions in all three models.

- The cliff PQ is a uniform plane making an angle  $\alpha$  with the horizontal where  $\sin \alpha = 0.8$ .
- A stone loses no speed at the bottom of the cliff when it changes direction at Q.
- The mass of a stone is 5 kg.

To test his models, Hari places a flat stone at P and observes its motion sliding down the cliff and along the ground. After 11.4 seconds it comes to rest at S, 80 metres from Q.

In **Model A**, it is also assumed that all the surfaces are smooth.

- (i) Show that Model A predicts that the speed of the stone at Q will be  $35.4 \text{ m s}^{-1}$ . Write down the predicted speed of the stone when it is at S.

Give one reason why Model A is not suitable. [6]

In **Model B**, it is assumed that the stone is subject to a constant resistance force throughout the motion.

- (ii) Show that, if the resistance force is 19.6 N, Model B predicts that the stone will come to rest at S. [4]

Hari calculates the stone's time from P to S based on Model B and a resistance of 19.6 N. He finds it is not the same as the observed time and so he refines the model further.

In **Model C** it is assumed that the resistance forces are different, but constant, during each of the two stages of the motion:  $F_1$  N between P and Q;  $F_2$  N between Q and S. As a result of a further experiment Hari estimates that  $F_2 = 24.5 \text{ N}$  and this value is assumed in Model C.

- (iii) Given that Model C predicts that the stone stops at S, find the value of  $F_1$ . [4]

- (iv) Find the time taken for the stone to travel from P to S as predicted by Model C. [3]

- (v) Give one reason why the trains might not be as safe as Model C suggests. [1]

END OF QUESTION PAPER

**Copyright Information**

OCR is committed to seeking permission to reproduce all third-party content that it uses in its assessment materials. OCR has attempted to identify and contact all copyright holders whose work is used in this paper. To avoid the issue of disclosure of answer-related information to candidates, all copyright acknowledgements are reproduced in the OCR Copyright Acknowledgements Booklet. This is produced for each series of examinations and is freely available to download from our public website ([www.ocr.org.uk](http://www.ocr.org.uk)) after the live examination series.

If OCR has unwittingly failed to correctly acknowledge or clear any third-party content in this assessment material, OCR will be happy to correct its mistake at the earliest possible opportunity.

For queries or further information please contact the Copyright Team, First Floor, 9 Hills Road, Cambridge CB2 1GE.

OCR is part of the Cambridge Assessment Group; Cambridge Assessment is the brand name of University of Cambridge Local Examinations Syndicate (UCLES), which is itself a department of the University of Cambridge.