

Tuesday 6 November 2012 – Morning

GCSE MATHEMATICS A

A501/02 Unit A (Higher Tier)

Candidates answer on the Question Paper.

OCR supplied materials:
None

- Other materials required:**
- Scientific or graphical calculator
 - Geometrical instruments
 - Tracing paper (optional)

Duration: 1 hour



Candidate forename		Candidate surname	
--------------------	--	-------------------	--

Centre number						Candidate number				
---------------	--	--	--	--	--	------------------	--	--	--	--

INSTRUCTIONS TO CANDIDATES

- Write your name, centre number and candidate number in the boxes above. Please write clearly and in capital letters.
- Use black ink. HB pencil may be used for graphs and diagrams only.
- Answer **all** the questions.
- Read each question carefully. Make sure you know what you have to do before starting your answer.
- Your answers should be supported with appropriate working. Marks may be given for a correct method even if the answer is incorrect.
- Write your answer to each question in the space provided. Additional paper may be used if necessary but you must clearly show your candidate number, centre number and question number(s).
- Do **not** write in the bar codes.

INFORMATION FOR CANDIDATES

- The number of marks is given in brackets [] at the end of each question or part question.
- The total number of marks for this paper is **60**.
- This document consists of **16** pages. Any blank pages are indicated.

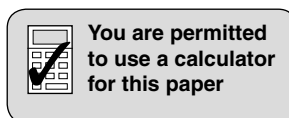

Formulae Sheet: Higher Tier

Area of trapezium = $\frac{1}{2}(a + b)h$

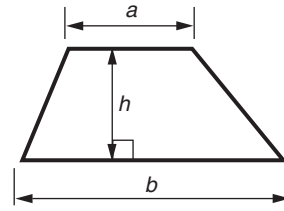

Volume of prism = (area of cross-section) \times length

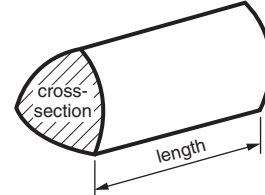

In any triangle ABC

Sine rule $\frac{a}{\sin A} = \frac{b}{\sin B} = \frac{c}{\sin C}$

Cosine rule $a^2 = b^2 + c^2 - 2bc \cos A$

Area of triangle = $\frac{1}{2}ab \sin C$

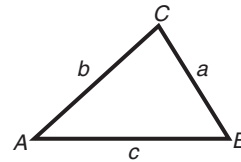

Volume of sphere = $\frac{4}{3}\pi r^3$

Surface area of sphere = $4\pi r^2$

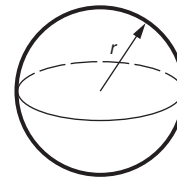

Volume of cone = $\frac{1}{3}\pi r^2 h$

Curved surface area of cone = $\pi r l$

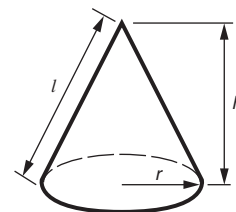

The Quadratic Equation

The solutions of $ax^2 + bx + c = 0$,
where $a \neq 0$, are given by

$$x = \frac{-b \pm \sqrt{b^2 - 4ac}}{2a}$$

PLEASE DO NOT WRITE ON THIS PAGE

- 1 (a) Joe and Pam planted crocus bulbs in their gardens.
They shared a bag of 250 crocus bulbs.
The table shows the colour of the flower from each bulb.

	Yellow	Purple	White	Totals
Joe	64	40		125
Pam	56		32	125
Totals	120			250

- (i) Complete the table.

[3]

- (ii) Write the ratio 64 : 56 as simply as possible.

(a)(ii) _____ [1]

- (b) Sumita bought a pack of 60 crocus bulbs which produced Yellow, Purple or White flowers.
The ratio Yellow : Purple : White was 7 : 5 : 3.

How many of the 60 bulbs produced White flowers?

(b) _____ [3]

- 2 (a) Mandi writes a questionnaire about music.
Here is one of her questions and the response boxes for it.

How many CDs do you own?			
0 - 5	<input style="width: 30px; height: 20px;" type="text"/>	5 - 10	<input style="width: 30px; height: 20px;" type="text"/>
10 - 15	<input style="width: 30px; height: 20px;" type="text"/>	15 - 20	<input style="width: 30px; height: 20px;" type="text"/>

Mandi has made two different types of error in the categories she has chosen.

Explain what these errors are.

1 _____

2 _____

[2]

- (b) Mandi analyses the length of time of each track on her CDs.
This table summarises the results.

Length (t seconds)	Frequency
$0 < t \leq 100$	2
$100 < t \leq 200$	10
$200 < t \leq 300$	15
$300 < t \leq 400$	9
$400 < t \leq 500$	3
$500 < t \leq 600$	1

Calculate an estimate of the mean length of time of these tracks.

(b) _____ seconds [4]

3 Calculate.

(a) $\frac{3.36 + 139.2}{2.4 \times 1.25}$

(a) _____ [1]

(b) $\sqrt{6.2^3 - 7.288}$

(b) _____ [1]

4 (a) Find the value of $6x^2$ when $x = -4$.

(a) _____ [2]

(b) Find the first 3 terms of the sequence whose n th term is $4n + 3$.

(b) _____ [2]

(c) Factorise completely.

$$6y^2 + 9y$$

(c) _____ [2]

(d) Solve.

$$2x + 7 = 6x - 8$$

(d) _____ [3]

(e) Rearrange this formula to make x the subject.

$$y = 4x + 6$$

(e) _____ [2]

- 5 In this question, use a ruler and a pair of compasses.
Leave in your construction lines.

The scale drawing ABCD shows Neil's garden.
AB is the wall of Neil's house.

Scale: 1 cm represents 200 cm

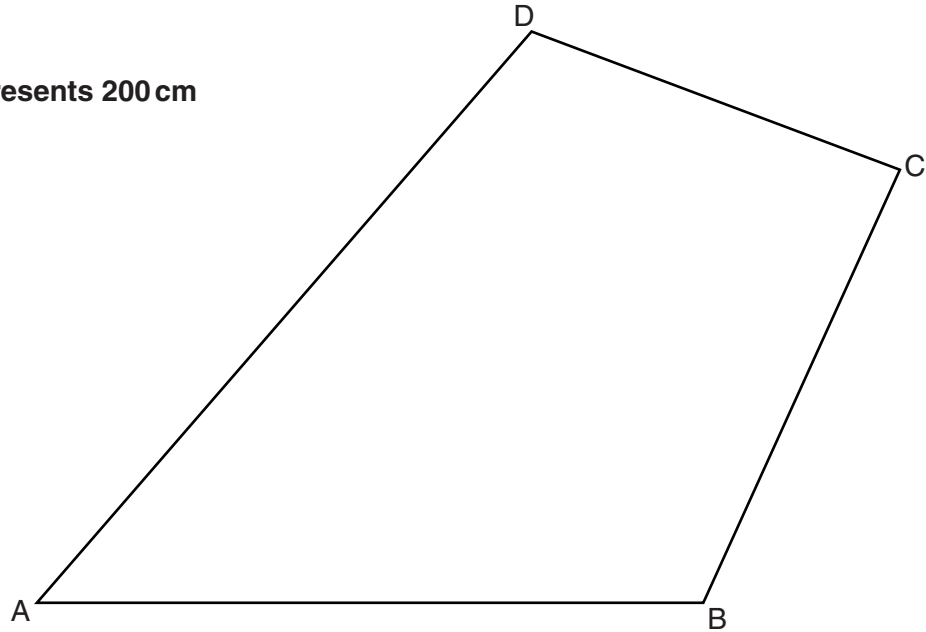

Construct the perpendicular from D to AB.
Hence find the shortest actual distance, in metres, from corner D of the garden to the house.

_____ m [4]

6 (a) Express 24 as a product of its prime factors.

(a) _____ [2]

(b) Two numbers have a highest common factor of 24 and a least common multiple of 4200.
Neither of the numbers is 24.

Find the two numbers, showing how you decide.

(b) _____ and _____ [3]

- 7 A small garden table has legs 85 cm long which can be fixed in various positions.

(a)

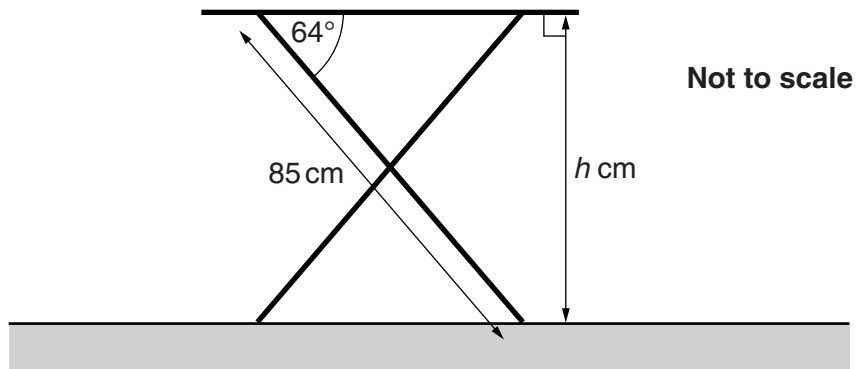

Calculate the height, h cm, of the table when the legs make an angle of 64° with the horizontal.

(a) _____ cm [3]

(b)

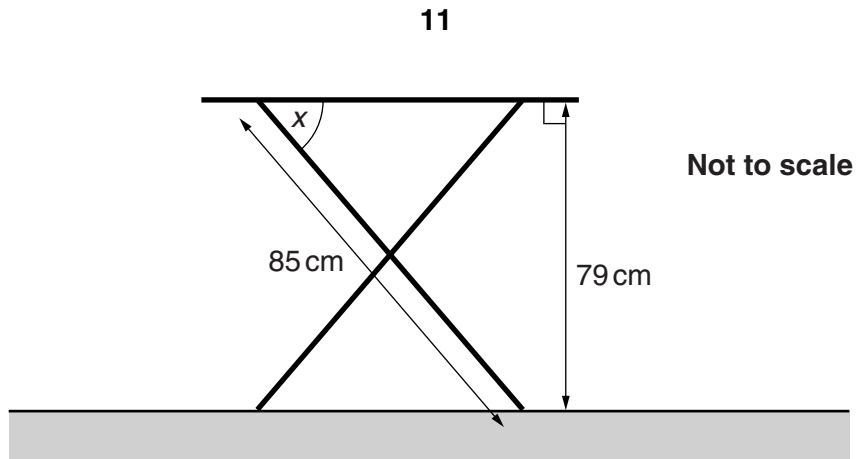

Calculate angle x when the height of the table is 79 cm.
Give your answer in degrees correct to 1 decimal place.

(b) _____ ° [3]

- 8 Colin and Peter climbed Binsey Hill in the Lake District. Peter printed out this graph from his satnav.

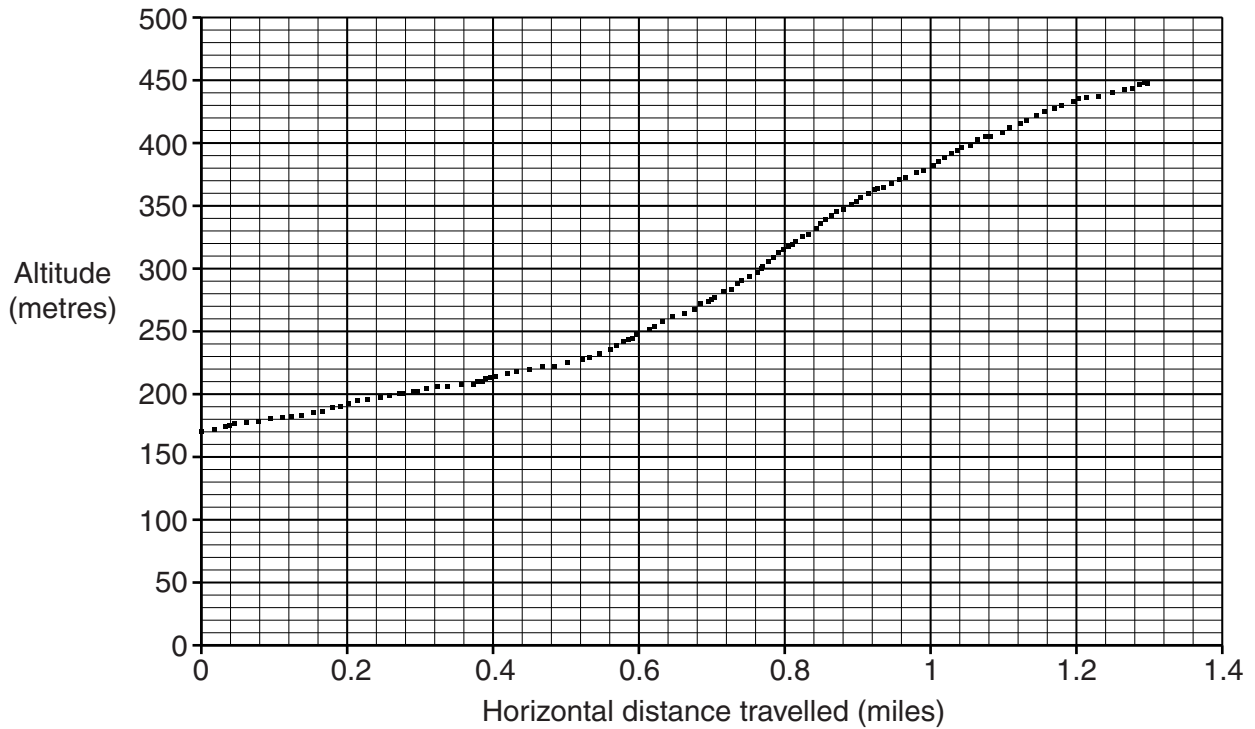

Colin wanted to know how far they had actually walked.

- (a) He used this triangle to estimate the distance they walked going up Binsey Hill.

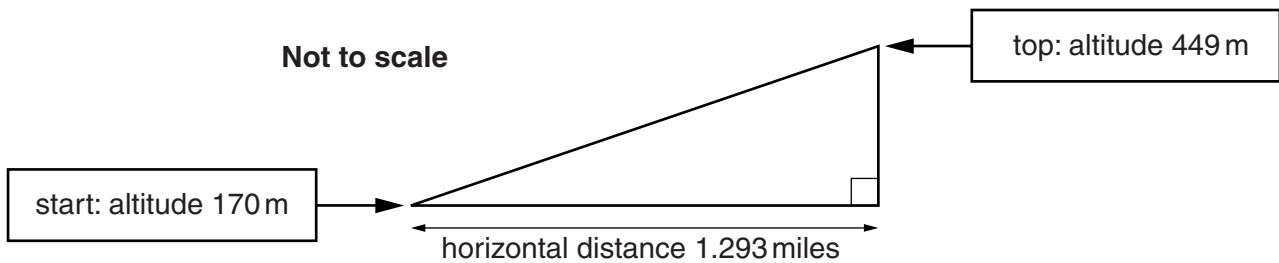

Calculate the distance in metres along the hypotenuse of this triangle. Use the fact that 1 mile = 1609 metres.

(a) _____ metres [5]

- (b) Describe how Colin's method could be improved to calculate a better estimate of the actual distance they walked on their way up Binsey Hill.
You do not need to carry out any calculations.

[1]

- 9 This table summarises the wages of employees at a company.

Wage (£ w thousand)	Frequency
$10 < w \leq 15$	5
$15 < w \leq 20$	8
$20 < w \leq 30$	20
$30 < w \leq 40$	22
$40 < w \leq 50$	16
$50 < w \leq 70$	4

Construct a histogram to represent this distribution.

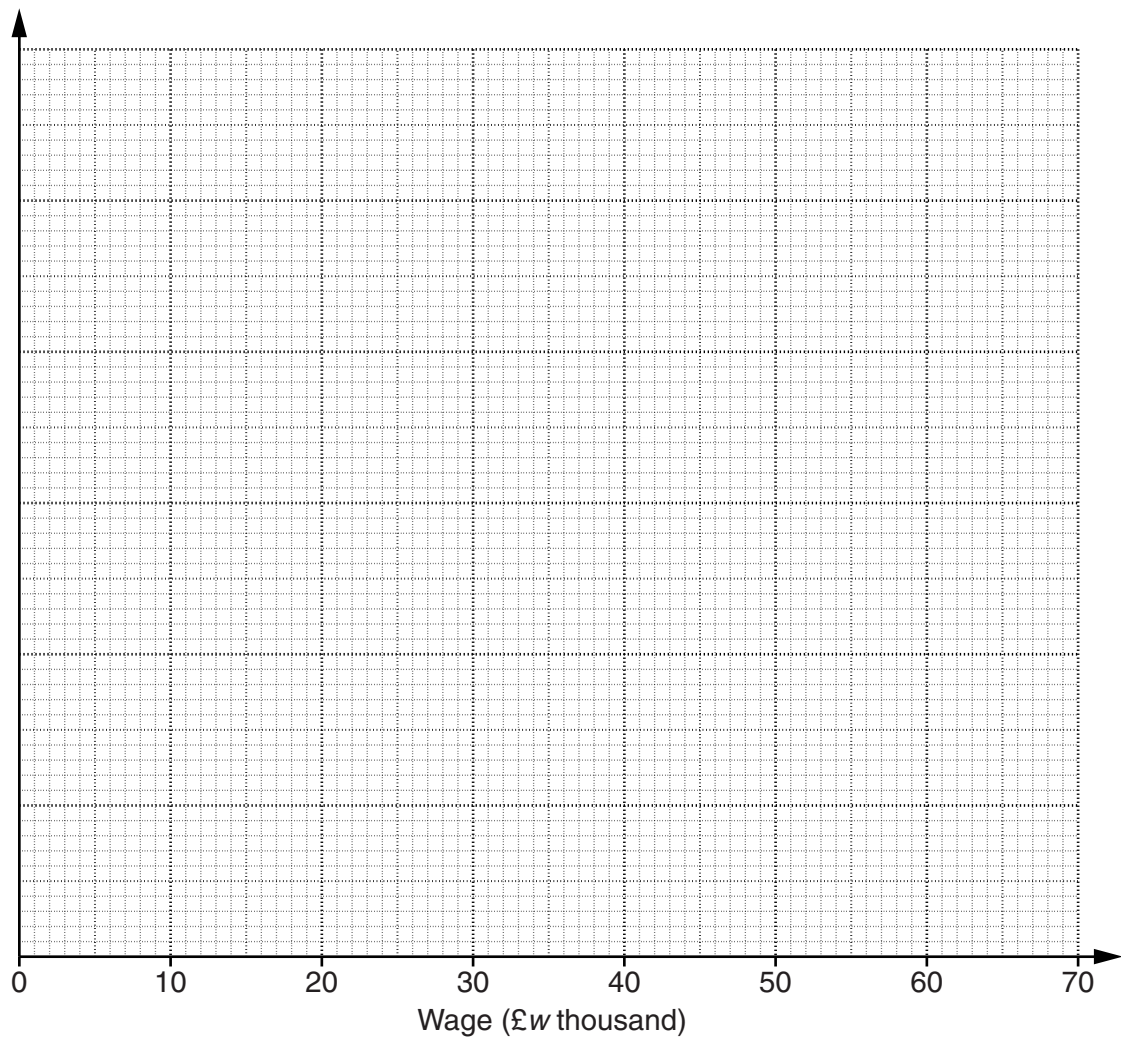

[4]

10 (a) You are given that $5a(a - 1) + pa + r = 5a^2 + 7a + 9$.

Find the values of p and r that make this an identity.

(a) $p =$ _____

$r =$ _____ [2]

(b) Rearrange the following to make c the subject.

$$5c + 6d = cn + 9d$$

(b) _____ [3]

TURN OVER FOR QUESTION 11

11 You are given that $f(x) = 5x - 7$.

(a) Calculate $f(5.2)$.

(a) _____ [1]

(b) Work out an expression for $f(2 + 3t)$, writing your answer in the form $at + b$.

(b) _____ [3]



Copyright Information

OCR is committed to seeking permission to reproduce all third-party content that it uses in its assessment materials. OCR has attempted to identify and contact all copyright holders whose work is used in this paper. To avoid the issue of disclosure of answer-related information to candidates, all copyright acknowledgements are reproduced in the OCR Copyright Acknowledgements Booklet. This is produced for each series of examinations and is freely available to download from our public website (www.ocr.org.uk) after the live examination series.

If OCR has unwittingly failed to correctly acknowledge or clear any third-party content in this assessment material, OCR will be happy to correct its mistake at the earliest possible opportunity.

For queries or further information please contact the Copyright Team, First Floor, 9 Hills Road, Cambridge CB2 1GE.

OCR is part of the Cambridge Assessment Group; Cambridge Assessment is the brand name of University of Cambridge Local Examinations Syndicate (UCLES), which is itself a department of the University of Cambridge.