

| | | |
|---------------|---------------|------------------|
| Surname | Centre Number | Candidate Number |
| First name(s) | | 2 |



GCE A LEVEL

A420U10-1



FRIDAY, 8 OCTOBER 2021 – MORNING

PHYSICS – A level component 1
Newtonian Physics

2 hours 15 minutes

| | | | | For Examiner's use only | | |
|------------------|----|----|--|-------------------------|--------------|--------------|
| | | | | Question | Maximum Mark | Mark Awarded |
| Section A | 1. | 11 | | | | |
| | 2. | 9 | | | | |
| | 3. | 9 | | | | |
| | 4. | 9 | | | | |
| | 5. | 20 | | | | |
| | 6. | 15 | | | | |
| | 7. | 7 | | | | |
| Section B | 8. | 20 | | | | |
| | | | | Total | 100 | |

ADDITIONAL MATERIALS

In addition to this examination paper, you will require a calculator and a **Data Booklet**.

INSTRUCTIONS TO CANDIDATES

Use black ink or black ball-point pen. Do not use gel pen or correction fluid.

You may use a pencil for graphs and diagrams only.

Write your name, centre number and candidate number in the spaces at the top of this page.

Answer **all** questions.

Write your answers in the spaces provided in this booklet. If you run out of space, use the additional page(s) at the back of the booklet, taking care to number the question(s) correctly.

INFORMATION FOR CANDIDATES

This paper is in 2 sections, **A** and **B**.

Section A: 80 marks. Answer **all** questions. You are advised to spend about 1 hour 35 minutes on this section.

Section B: 20 marks. Comprehension. You are advised to spend about 40 minutes on this section.

The number of marks is given in brackets at the end of each question or part-question.

The assessment of the quality of extended response (QER) will take place in question **6(a)**.



OCT21A420U10101

SECTION A*Answer all questions.*

1. (a) State the conditions needed for a body to be in equilibrium. [2]

.....

.....

.....

- (b) The diagram shows a hinged trapdoor into a loft. The door is propped open at an angle of 33° to the horizontal by a rod that pushes on it at right angles at a point 0.06 m from the end of the trapdoor.

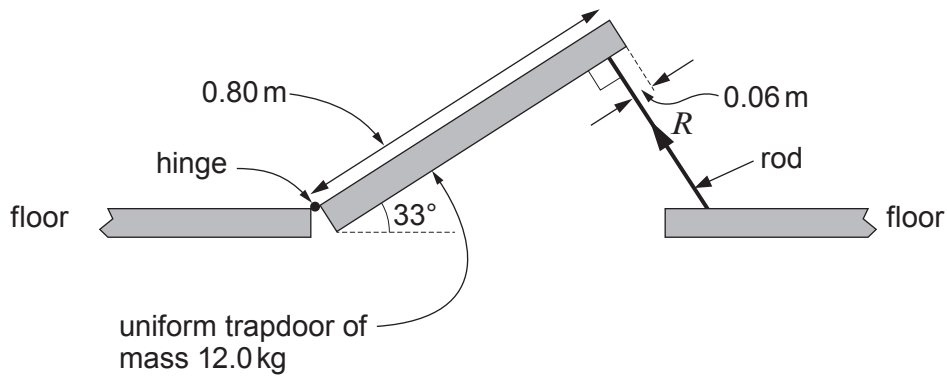

- (i) Use the data in the diagram to answer the following.
- I. Calculate the moment about the hinge of the trapdoor's weight. [2]

.....

.....

.....

- II. Show that the force, R , that the rod exerts on the trapdoor is approximately 50 N. [2]

.....

.....

.....



III. Calculate the **horizontal component** of the force that the hinge exerts on the trapdoor. [2]

.....

.....

.....

.....

(ii) The line of action of force, R , is shown on the diagram below.

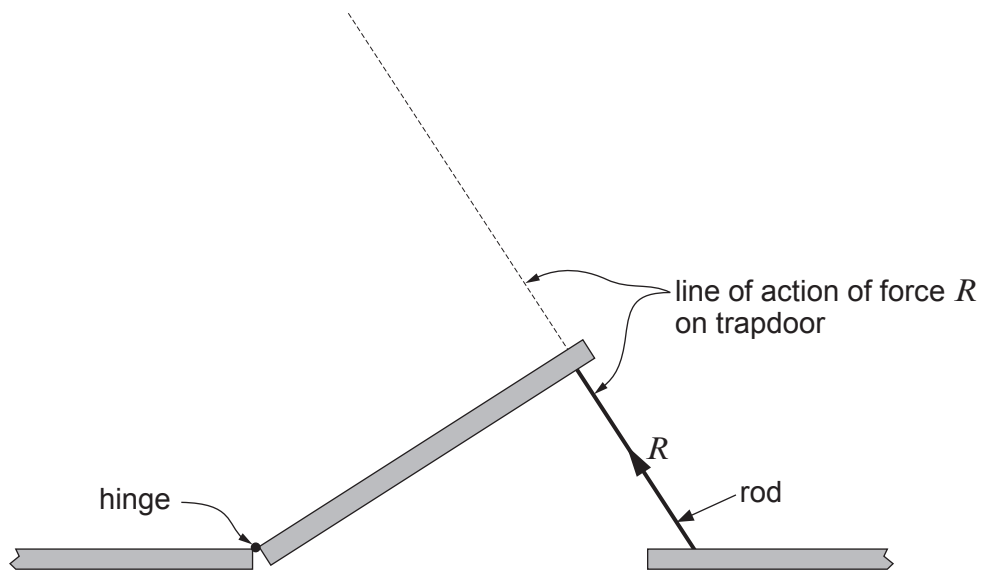

- I. **Draw** the line of action of the trapdoor's weight, **and mark the point P** at which it intersects the line of action of R (shown above). [1]
- II. Darren claims that, according to the principle of moments, the line of action of the force exerted on the trapdoor by the hinge must also pass through point P. Evaluate this claim. [2]

.....

.....

.....

.....



BLANK PAGE

**PLEASE DO NOT WRITE
ON THIS PAGE**



2. (a) A body moves in a straight line with constant acceleration, a . Its initial velocity is u . **Use a sketched and labelled velocity-time graph** to show that the body's displacement at time, t , is:

$$x = ut + \frac{1}{2}at^2 \quad [3]$$

.....

.....

.....

.....

.....



- (b) Ali uses an electronic system to release a steel ball from rest and to record its time, t , to fall through a measured height, h . He repeats the procedure for different values of h . The theoretical relationship between t and h is:

$$h = \frac{1}{2}gt^2$$

where g is the acceleration due to gravity.

A ln-ln graph is plotted below from Ali's results.

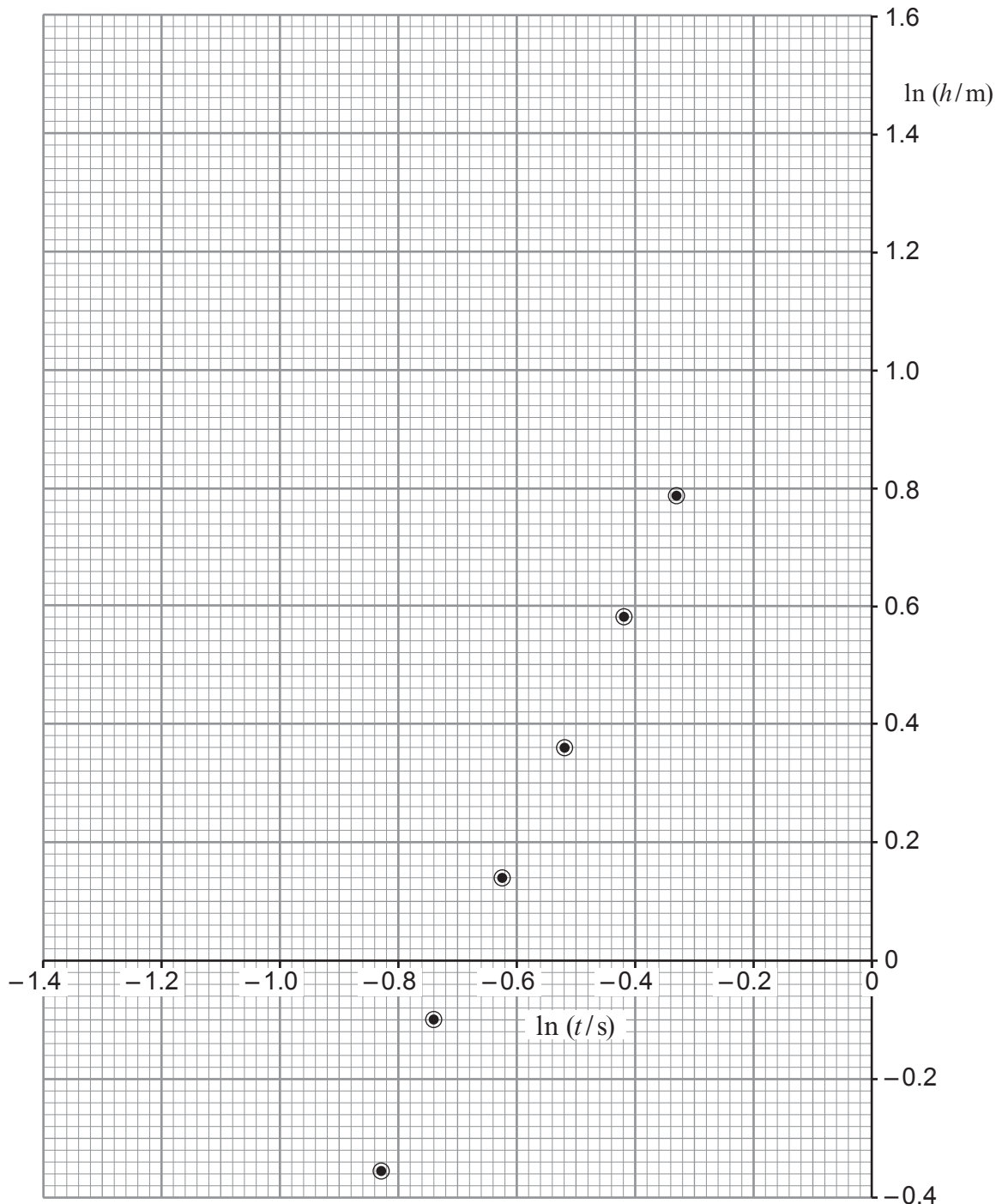

3. Charlotte uses the apparatus shown to determine the speed at which a staple leaves a staple gun.

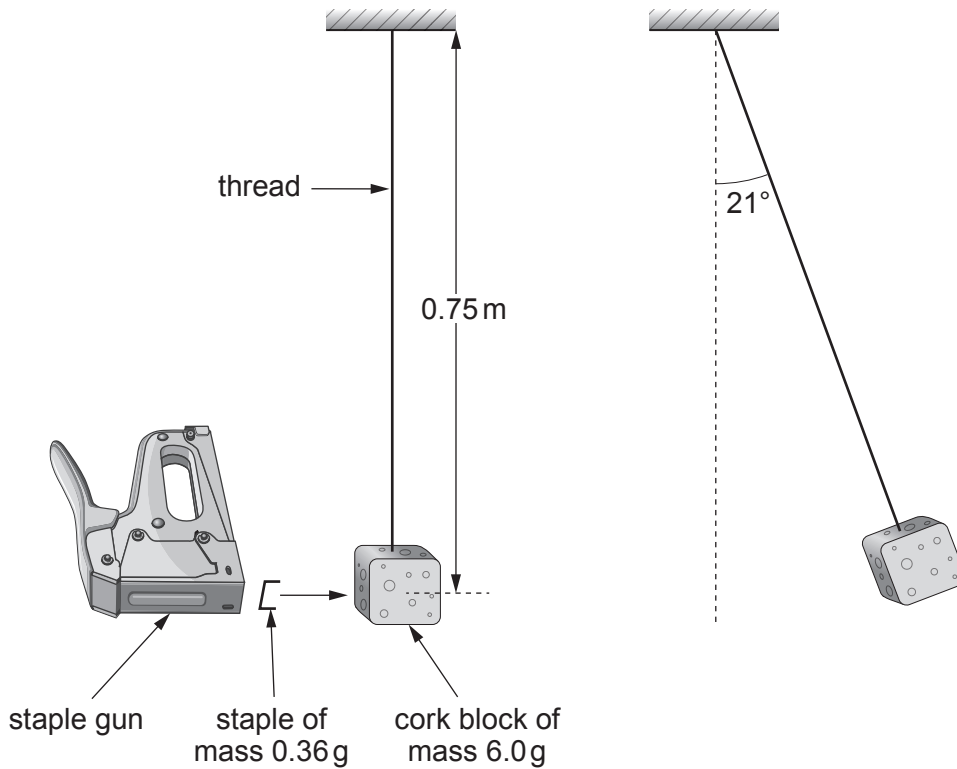

The cork block is set moving to the right by the collision, coming to rest momentarily when the thread is at an angle of 21° to the vertical.

- (a) (i) State the *principle of conservation of energy*. [1]

.....

.....

- (ii) Show that the block's speed just after the staple has **embedded itself** is approximately 1 ms^{-1} . [4]

.....

.....

.....

.....

.....

.....

.....

.....



(b) Determine the speed of the staple just before it entered the block. [2]

.....

.....

.....

.....

(c) Charlotte claims that the block would have swung higher if the staple had bounced back off the block instead of embedding itself. Evaluate this claim. [2]

.....

.....

.....

.....

A420U101
09

| |
|---|
| |
| 9 |



4. (a) A car travels around a bend in a road at a constant speed of 8.0 m s^{-1} . It takes 2.5 s to go from A to B. The diagram shows the car's velocities at A and B.

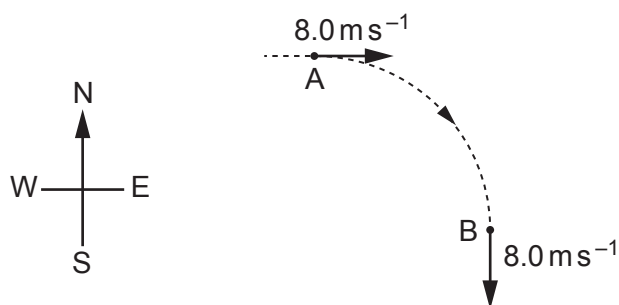

Determine the magnitude and **compass direction** of the car's **mean** acceleration as it goes from A to B. [3]

.....

.....

.....

.....

.....

- (b) In special circumstances an electron has been made to orbit a nucleus in a circular orbit of radius 0.37 mm .

(i) Comment on the radius of this atomic orbit. [1]

.....

(ii) Assuming the charge on the nucleus to be $+e$, show that the speed of the electron is approximately 800 m s^{-1} . [3]

.....

.....

.....

.....

.....



(iii) Calculate the frequency at which the electron orbits.

[2]

.....

.....

.....

.....

| |
|---|
| |
| 9 |



5. (a) A light spring hangs from a fixed support. A mass of 0.200 kg is fastened to its lower end, displaced **upwards** from its equilibrium position, and released at time $t = 0$.

A data-logger is used to produce a graph of displacement, x (from the equilibrium position) against time, t .

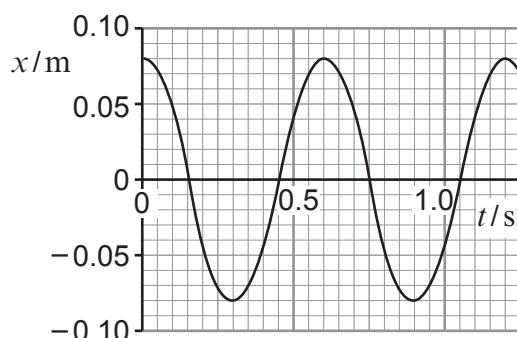

- (i) Sally measured the **equilibrium extension** of the spring, when loaded with the 0.200 kg mass, recording it as 90 mm. Evaluate whether or not this is consistent with the period of the oscillations. [4]

.....

.....

.....

.....

.....

.....

.....

.....

.....

.....

- (ii) I. **Mark a point, P**, on the graph at which the acceleration is upwards and has its greatest value. [1]

- II. Calculate this acceleration. [2]

.....

.....

.....

.....

.....



- (iii) I. Calculate the kinetic energy of the mass at $t = 0.10$ s. [3]

.....

.....

.....

.....

.....

- II. Between $t = 0$ and $t = 0.15$ s, the mass gains kinetic energy and loses gravitational potential energy. Without further calculation, explain why the gain in kinetic energy is considerably less than the loss of gravitational potential energy. [2]

.....

.....

.....



(b) The mass-spring system of part (a) is made to perform forced oscillations.

(i) State the difference between forced oscillations and natural oscillations. [2]

.....

.....

.....

(ii) **Sketch a resonance curve** for these forced oscillations on the axes provided. Scales are not required. **Label the numerical value** of the resonance frequency at the appropriate place on the frequency axis. [3]

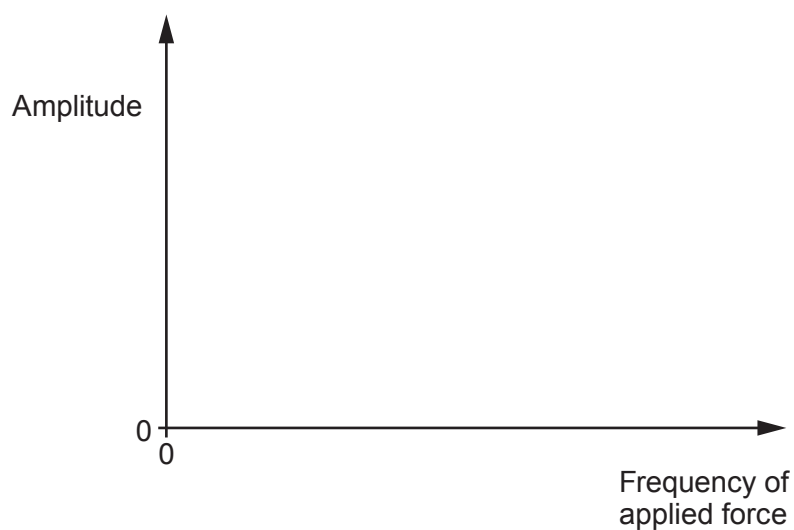

(c) Sally says "Damping should always be avoided because it involves energy dissipation". Evaluate this claim. [3]

.....

.....

.....

.....

.....

.....



BLANK PAGE

**PLEASE DO NOT WRITE
ON THIS PAGE**



- (b) (i) One assumption of the kinetic theory of ideal gases is that a gas consists of particles (molecules) in rapid random, translational, motion. State **two** other assumptions of the ideal gas theory. [2]

.....

.....

.....

- (ii) A cylinder of volume 0.050 m^3 contains 20.0 mol of oxygen gas at a pressure of $1.00 \times 10^6\text{ Pa}$. [Relative molecular mass of oxygen = 32.0.]

- I. Calculate the rms speed of the molecules. [3]

.....

.....

.....

.....

.....

.....

- II. The oxygen in the cylinder is now replaced by 20.0 mol of helium [relative molecular mass = 4.0] at the same temperature. Ciaran claims that both the pressure and the rms speed of the molecules will be the same as in the previous part. Evaluate both of these claims. [4]

.....

.....

.....

.....

.....

.....



7. An insulated cylinder fitted with a leak-proof piston contains 0.125 mol of helium gas.

The piston is now allowed to move, so that the gas expands quickly from point **A** to point **B**, as shown. No heat enters or leaves the gas during the expansion.

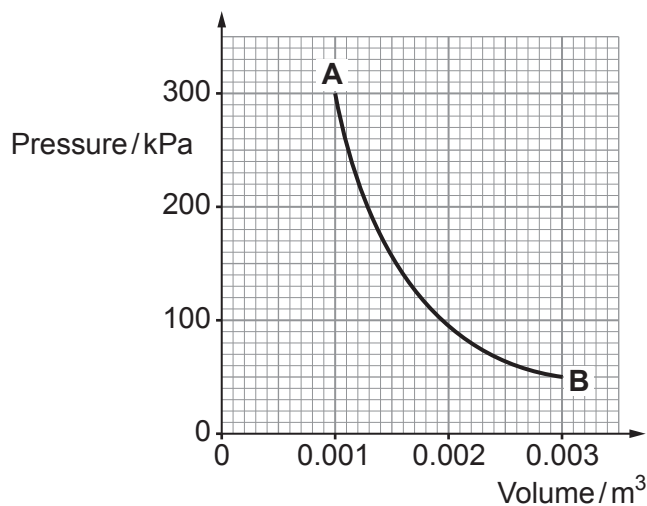

- (a) Calculate the temperatures of the gas at **A** and at **B**. [3]

.....

.....

.....

.....

- (b) Use the graph to determine (approximately) the work done by the expansion. [2]

.....

.....

.....

.....

- (c) Use the *first law of thermodynamics* to explain why a fall of temperature is to be expected over **AB**. [2]

.....

.....

.....

.....



BLANK PAGE

**PLEASE DO NOT WRITE
ON THIS PAGE**



SECTION B

Answer all questions.

8. Read through the following article carefully.

Paragraph

Build Your Own Strainmeter in an A-level Physics Classroom

The first questions that need answering are: what is a strainmeter and who might use one? The answer to the first question is that a strainmeter measures the deformation or change in length of an object under stress. A variety of people, ranging from engineers to geophysicists, use these meters to measure the deformation of buildings, aircraft wings, railway lines and even the Earth itself.

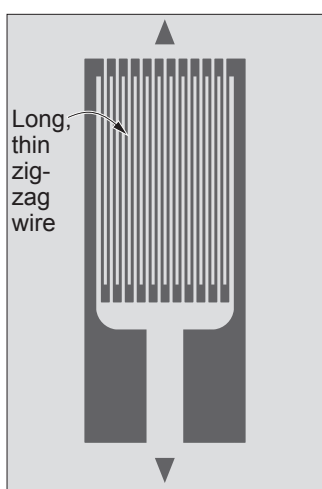

Figure 1

Now, the first thing we need is some kind of sensor and a very popular choice is something called a strain gauge. It turns out that this is only a long thin zig-zag piece of wire (see **Figure 1**).

The longer you make the zig-zag wire, the greater its resistance and it is this resistance that is the key to its operation. You glue the strain gauge to whatever it is that is going to deform. When it deforms, the strain gauge also deforms and the resistance of the wire changes because it has changed length.

So, what we have to do now is measure this change in resistance. For this we use something called a Wheatstone Bridge. One rather clever Wheatstone Bridge set-up is shown in **Figure 2**. It employs 4 identical strain gauges (SG1–4) so that every strain gauge has a pd of $+\frac{1}{2}V_0$ across it and the pd between points A and B is zero. Meaning that the default reading on our voltmeter in **Figure 2** is zero.

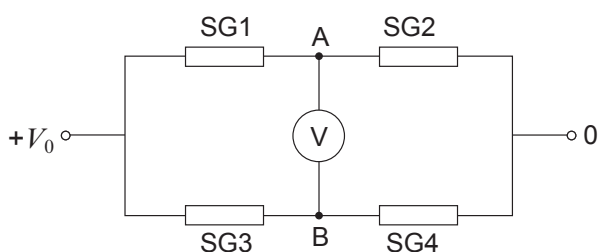

Figure 2

However, one of these strain gauges, SG2, has been glued to the material under strain and the other three are not glued to anything, which means they are not under strain. Hence, ideally, only the resistance of SG2 will change. If SG2 is stretched, so that the zig-zag wires become longer, then its resistance will increase. This leads to a positive pd between A and B (leading to a positive reading on the voltmeter). If SG2 is compressed, the reading on the voltmeter will be negative.

There are two ways in which this set-up is designed to be unaffected by temperature changes. First, the identical strain gauges are made of an alloy called constantan, which is an alloy designed to have a resistance that does not vary with temperature. Second, the gauges are all in thermal contact with each other.

The strain gauge in **Figure 1** is most sensitive when it is stretched (or compressed) in the direction of the arrows. This means that if you have three of these you can measure the strain in three dimensions and wherever on the structure that you glue the strain gauges (see **Figure 3**).



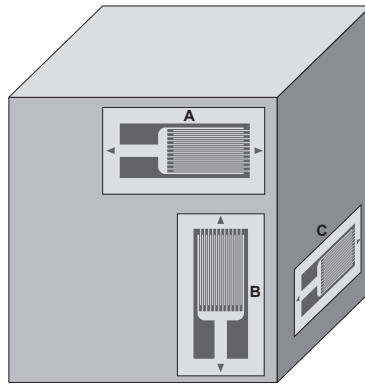

Figure 3

Paragraph

Now that we have our sensor the question is “How do we measure the output from it?” 8
 We need a voltmeter. We will take an ammeter and convert it into a voltmeter.

An ammeter consists of a rotating coil of negligible resistance attached to a spring, and a magnet. A pointer is attached to the rotating coil and some sort of a scale is also useful. Ideally, you get the magnetic field to be shaped as shown in Figure 4. 9

The B -field has a constant magnitude at the outside of the iron core and is always at right angles to the wires of the coil going into and out of the paper. This all leads to forces on the coil that make it turn clockwise when the current is in the direction shown.

The spring obeys Hooke’s law and so the equilibrium deflection of the needle is proportional to the current in the coil. However, there is a problem that needs to be ironed out. After all, any mass on a spring is an oscillating system and a pointer oscillating back and forth around the correct reading makes it difficult to read the correct reading accurately. Fortunately, the oscillations can be eliminated using air resistance acting on something with sufficient area attached to the coil. 10

Now we need to convert the ammeter into a voltmeter. Look at Figure 5: the micro-ammeter combined with a $1\text{ k}\Omega$ resistor will give a reading (in μA) that is equal to the pd, V , in volt. A scale that goes from $0\text{--}10\ \mu\text{A}$ has been converted to a scale that goes from $0\text{--}10\text{ V}$. 11

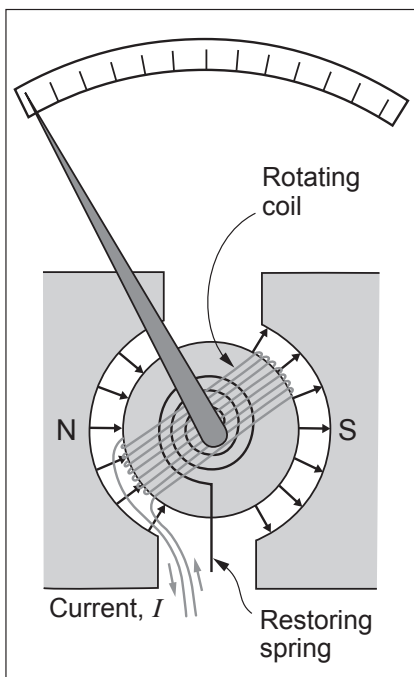

Figure 4

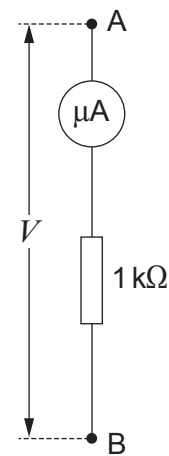

Figure 5



Answer the following questions in your own words. Direct quotes from the original article will not be awarded marks.

- (a) Explain what relationship you would expect between the resistance of the strain gauge and strain (see paragraph 3). [2]

.....

.....

.....

- (b) Explain why the voltmeter reading is negative when strain gauge 2 (SG2) is compressed (see paragraphs 4 and 5 and Figure 2). [3]

.....

.....

.....

.....

- (c) Explain the advantage of making all 4 strain gauges in Figure 2 from constantan (see also paragraphs 4, 5 and 6). [2]

.....

.....

.....

- (d) The structure in Figure 3 is put under compression in the vertical direction. Explain what happens to the resistance of the 3 strain gauges A, B, C. [3]

.....

.....

.....

.....



- (e) Explain why the coil in Figure 4 will turn clockwise (see Figure 4 and paragraph 9). [3]

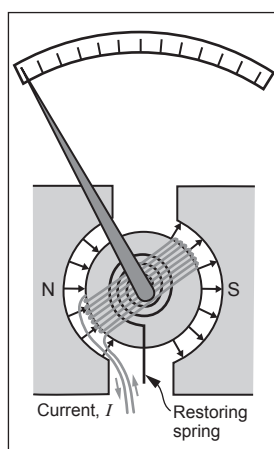

Figure 4

.....

.....

.....

.....

.....

- (f) Explain why the deflection of the pointer is proportional to the current (you will need to refer to a magnetic force equation in your answer, see paragraph 10). [3]

.....

.....

.....

.....

.....

**TURN OVER FOR THE LAST
PARTS OF THE QUESTION**



(g) State and explain the type of damping that should be provided so that the pointer provides the correct reading quickly (see paragraph 10). [2]

.....

.....

.....

(h) Andrea states that the author has made a mistake because the resistor in Figure 5 will give a current in μA **that is a thousand times the pd in V**. Determine whether Andrea is correct (see paragraph 11 and Figure 5). [2]

.....

.....

.....

.....

END OF PAPER

| |
|----|
| |
| 20 |



BLANK PAGE

**PLEASE DO NOT WRITE
ON THIS PAGE**



BLANK PAGE

**PLEASE DO NOT WRITE
ON THIS PAGE**



BLANK PAGE

**PLEASE DO NOT WRITE
ON THIS PAGE**

