

Surname	Centre Number	Candidate Number
First name(s)		2



GCE AS

B420U10-1



WEDNESDAY, 18 MAY 2022 – MORNING

PHYSICS – AS component 1
Motion, Energy and Matter

1 hour 30 minutes

For Examiner's use only		
Question	Maximum Mark	Mark Awarded
1.	11	
2.	10	
3.	12	
4.	10	
5.	11	
6.	11	
7.	10	
Total	75	

ADDITIONAL MATERIALS

In addition to this paper, you will require a calculator and a **Data Booklet**.

INSTRUCTIONS TO CANDIDATES

Use black ink or black ball-point pen. Do not use gel pen or correction fluid.

You may use a pencil for graphs and diagrams only.

Write your name, centre number and candidate number in the spaces at the top of this page.

Answer **all** questions.

Write your answers in the spaces provided in this booklet. If you run out of space, use the continuation page(s) at the back of the booklet, taking care to number the question(s) correctly.

INFORMATION FOR CANDIDATES

The total number of marks available for this paper is 75.

The number of marks is given in brackets at the end of each question or part-question.

You are reminded to show all working. Credit is given for correct working even when the final answer is incorrect.

The assessment of the quality of extended response (QER) will take place in 4(a).

Answer **all** questions.

1. (a) (i) State the difference between vector and scalar quantities. [1]

.....

.....

- (ii) Place the following quantities in the correct column in the table below. [2]

speed distance displacement work energy acceleration

Vector	Scalar

- (b) Showing your reasoning determine the resultant force ΣF in the free body diagram below. [3]

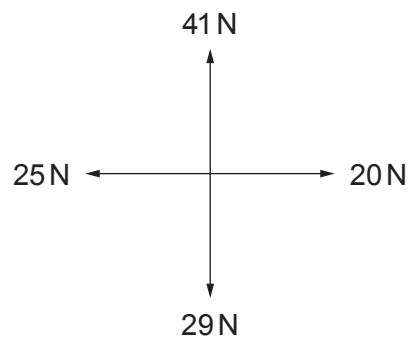

.....

.....

.....

.....

.....

(c) One of the equations of uniformly accelerated motion is given below:

$$x = ut + \frac{1}{2}at^2$$

Show that this equation is correct in terms of units.

[2]

.....

.....

.....

.....

.....

(d) An aeroplane has a maximum acceleration on the ground of 3.5 m s^{-2} . If its take-off speed is 115 m s^{-1} determine the minimum length of the runway required for it to achieve take-off speed. Assume it starts from rest. [3]

.....

.....

.....

.....

.....

B420U101
03

2. A cricket ball of mass 0.16 kg is thrown vertically upwards with a speed of 9.0 m s^{-1} , arriving back at ground level 1.7 seconds later with a speed of 7.0 m s^{-1} .

(a) State Newton's second law of motion in terms of momentum. [2]

.....
.....
.....

(b) (i) Calculate the work done against air resistance during the flight. [2]

.....
.....
.....
.....

(ii) By considering the total change in momentum during the flight find the mean force acting on the ball. [2]

.....
.....
.....
.....

(c) (i) A team-mate of the cricketer says the ball will take longer to complete the upward part of the journey than the downward part. Discuss if he is correct. [2]

.....
.....
.....
.....

(ii) At which point during the flight is air resistance at its minimum? Give a reason for your answer. [2]

.....
.....
.....
.....

BLANK PAGE

3. Tracey carried out an experiment to accelerate a glider of unknown mass, M , using a series of five different slotted masses each of mass 10 g. The acceleration, a , was found using the following apparatus:

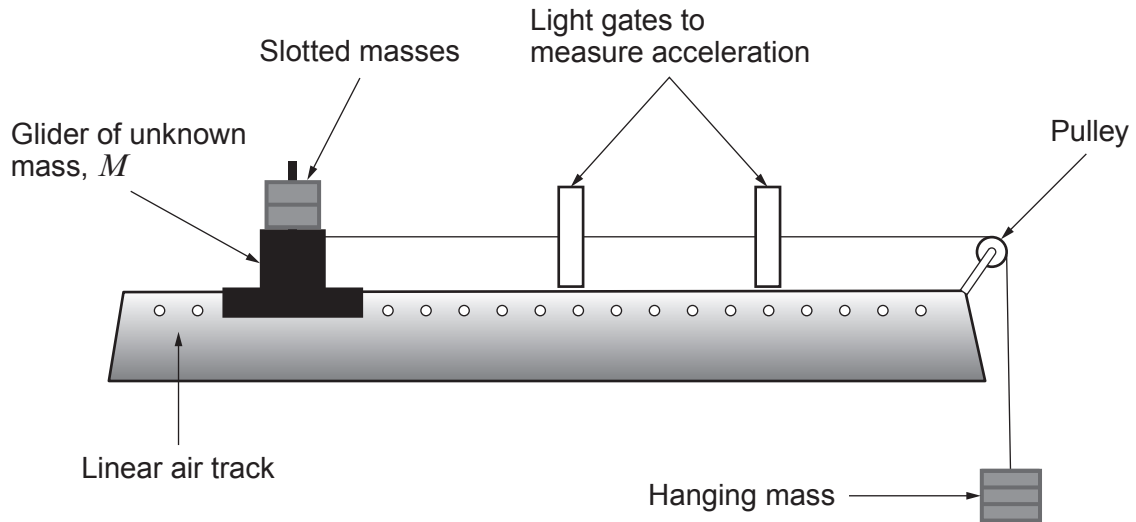

The total mass of the system is kept constant by removing one of the slotted masses from the hanging mass and placing it on the glider. The results were recorded in the table below.

Hanging mass / g	10.0	20.0	30.0	40.0	50.0
Acceleration / ms^{-2}	0.23	0.47	0.61	0.89	1.08

Tracey realised the force and acceleration were linked by the following equation:

$$F = (M + m)a \quad \text{where } m = 50 \text{ g}$$

- (a) **Plot a graph** of force against acceleration on the grid opposite. Space has been left below for the force values to be calculated.

[3]

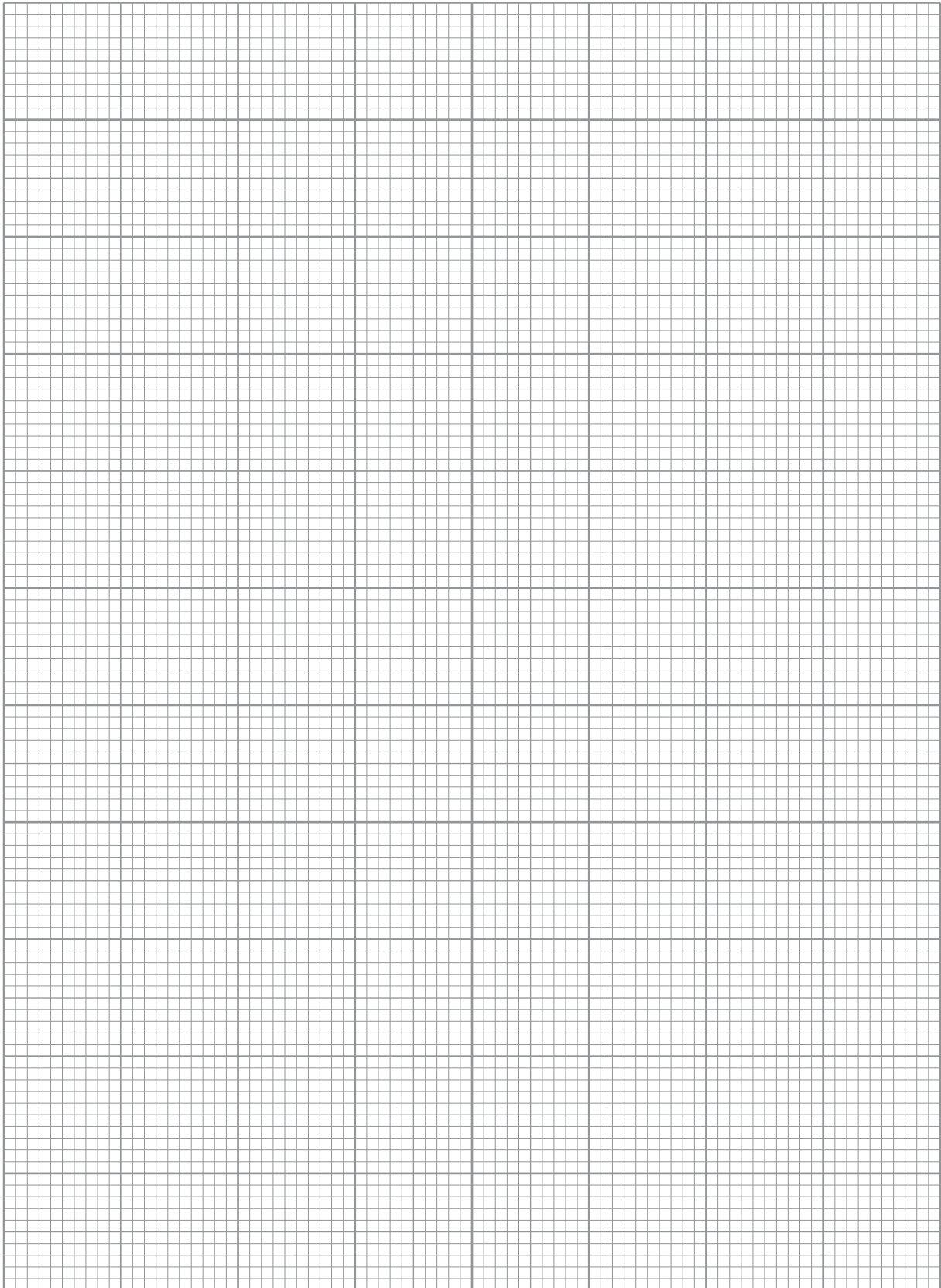

(b) Discuss to what extent your graph agrees with the equation given on page 6. [3]

.....

.....

.....

.....

.....

(c) Use your graph to determine the value of the unknown mass, M . [4]

.....

.....

.....

.....

.....

(d) Tracey predicts that the glider will continue with the same acceleration after the masses have hit the floor, evaluate if she is correct. [2]

.....

.....

.....

.....

12

BLANK PAGE

4. (a) Describe an experiment to determine the Young modulus of a metal wire.

[6 QER]

.....

.....

.....

.....

.....

.....

.....

.....

.....

.....

.....

.....

.....

.....

.....

.....

.....

.....

.....

.....

.....

.....

.....

- (b) The table below gives the Young modulus of selected metals.

Metal	Young modulus / GPa
aluminium	70
copper	130
iron	210
lead	16
steel	215

- (i) State which of the above materials is the stiffest **and** which is the least stiff. [1]

.....

.....

- (ii) A force of 80.0 N is applied to a copper wire 2.00 m long. If the diameter is 1.20 mm determine its extension. [3]

.....

.....

.....

.....

.....

5. (a) State the principle of moments.

[2]

.....

.....

.....

- (b) A shopkeeper places a sign of mass 8.0 kg outside her shop. She uses a uniform metal rod of mass 1.40 kg and length 2.40 m, along with a supporting cable as shown below.

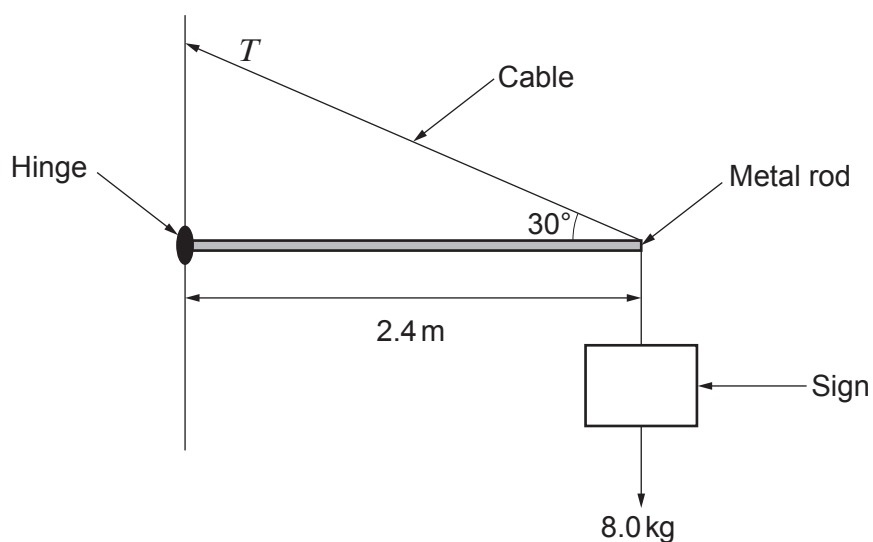

- (i) Determine the tension, T , in the cable.

[4]

.....

.....

.....

.....

.....

.....

.....

.....

- (ii) The shopkeeper decides to use a copper wire of diameter 1.0 mm and breaking stress $3.0 \times 10^8 \text{ Pa}$ as the supporting cable. Evaluate whether the sign will be secure. [3]

.....

.....

.....

.....

.....

- (c) Discuss whether or not the shopkeeper should be allowed to erect the sign without consulting the local council planning department or a qualified engineer. [2]

.....

.....

.....

.....

.....

11

6. (a) The table below shows information about some subatomic particles.

Particle	Symbol	Quark combination (if any)	Charge	Baryon number	Lepton number
neutron	n				
electron neutrino	ν_e				
pion	π^+				
positron	e^+				

(i) **Complete** the table above. [4]

(ii) State which **one** of the above particles is usually classed as an antiparticle. [1]

(iii) State **one** difference **and** one similarity between a charged particle and its antiparticle. [1]

- (b) (i) The following reaction has been observed in the large hadron collider at CERN.

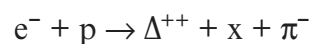

where Δ^{++} is a first generation baryon. Identify particle x. Justify your answer using the conservation laws. [3]

(ii) Deduce which force is responsible for the interaction, giving a reason for your answer. [2]

BLANK PAGE

**TURN OVER FOR THE
LAST QUESTION**

7. The diagram below shows a section of the absorption spectrum of the Sun.

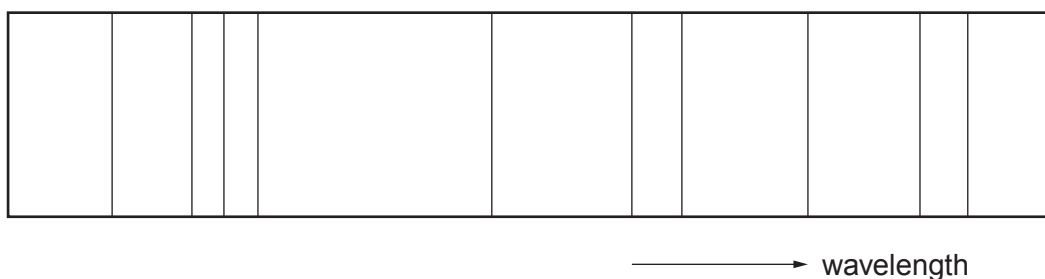

(a) Explain how this absorption spectrum arises **and** can be used to provide information about the elements from which the Sun is made. [3]

.....

.....

.....

.....

.....

.....

.....

(b) The star Polaris is 431 light years away and the intensity of its radiation reaching the earth is $4.1 \times 10^{-9} \text{ W m}^{-2}$. Determine its luminosity. (1 light year = $9.5 \times 10^{15} \text{ m}$) [3]

.....

.....

.....

.....

.....

.....

.....

(c) Calculate the diameter of Polaris given that its surface temperature is 7 250 K.

[4]

Examiner
only

.....

.....

.....

.....

.....

.....

.....

.....

.....

.....

.....

.....

.....

.....

.....

.....

.....

.....

.....

.....

.....

.....

.....

10

END OF PAPER

For continuation only.

(This area contains horizontal dotted lines for writing.)