

Surname	Centre Number	Candidate Number
First name(s)		2



GCE AS

B420U20-1



MONDAY, 6 JUNE 2022 – MORNING

PHYSICS – AS component 2
Electricity and Light

1 hour 30 minutes

For Examiner's use only		
Question	Maximum Mark	Mark Awarded
1.	13	
2.	17	
3.	13	
4.	20	
5.	12	
Total	75	

ADDITIONAL MATERIALS

In addition to this paper, you will require a calculator and a **Data Booklet**.

INSTRUCTIONS TO CANDIDATES

Use black ink or black ball-point pen. Do not use gel pen or correction fluid.

You may use a pencil for graphs and diagrams only.

Write your name, centre number and candidate number in the spaces at the top of this page.

Answer **all** questions.

Write your answers in the spaces provided in this booklet.

INFORMATION FOR CANDIDATES

The total number of marks available for this paper is 75.

The number of marks is given in brackets at the end of each question or part-question.

You are reminded to show all working. Credit is given for correct working even when the final answer is incorrect.

The assessment of the quality of extended response (QER) will take place in **Q3(c)(ii)**.

Answer **all** questions.

1. (a) Waves may be described as being either transverse or longitudinal. Explain the difference between the two types of waves. [3]

.....

.....

.....

.....

- (b) The following diagram shows a sinusoidal wave of frequency 20 Hz moving to the right on a rope at time $t = 0$ s.

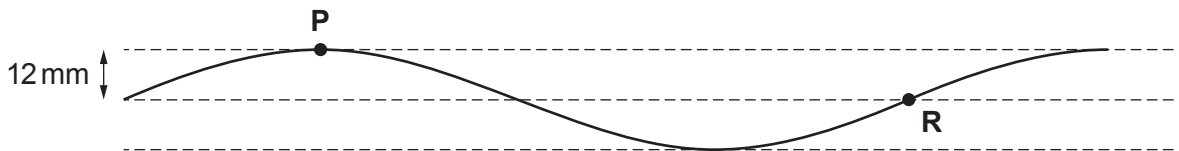

- (i) Sketch a graph of the displacement of **point P** against time for at least one complete cycle. Include scales on the axes. Space for calculations. [3]

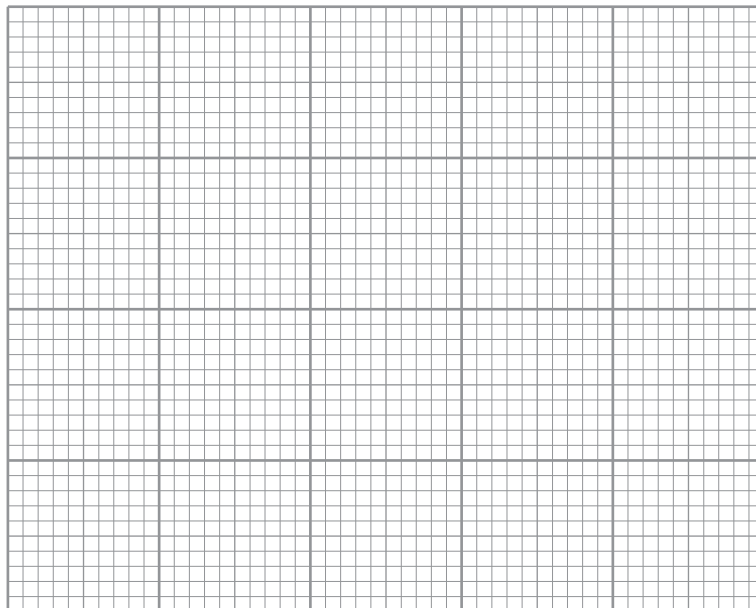

(ii) Compare the motions of points **P** and **R** on the rope. [2]

.....

.....

.....

.....

(c) (i) State the principle of superposition. [2]

.....

.....

.....

(ii) Waves in the form of single pulses are sent along a rope and travel in opposite directions as shown below. Sketch the motion of the pulses at times $t = 1.0\text{ s}$, 2.0 s and 3.0 s . [3]

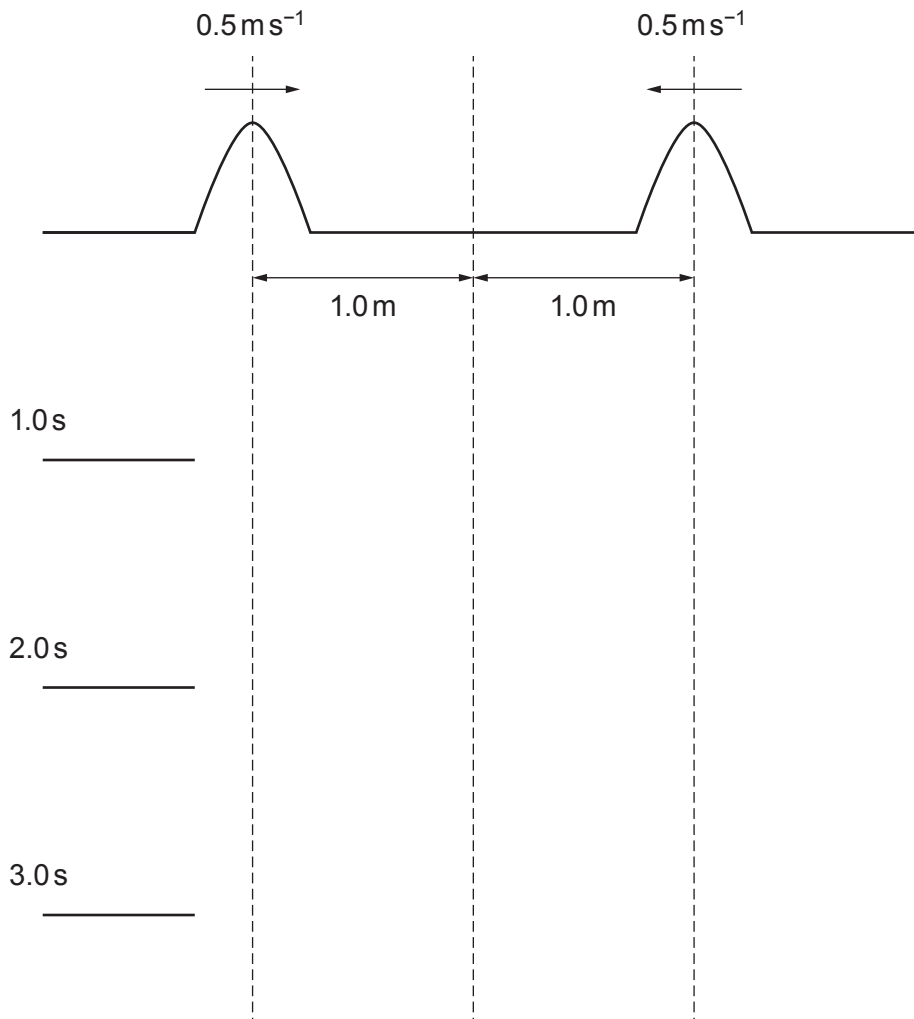

B420U201
03

2. (a) Explain the term *diffraction*.

[1]

.....

.....

.....

.....

- (b) The two diagrams show water wavefronts as they approach two slits of different sizes. Carefully **complete the diagrams** to show how the size of the slit affects the diffraction pattern observed for water waves. [3]

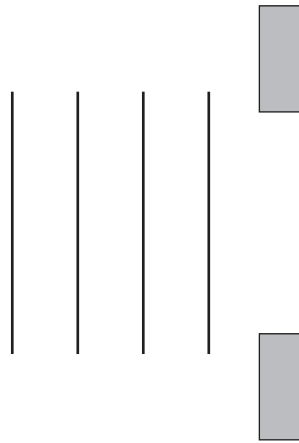

Diagram 1

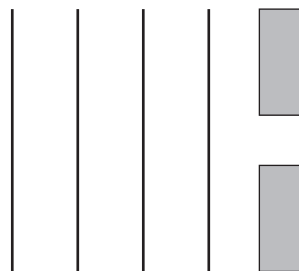
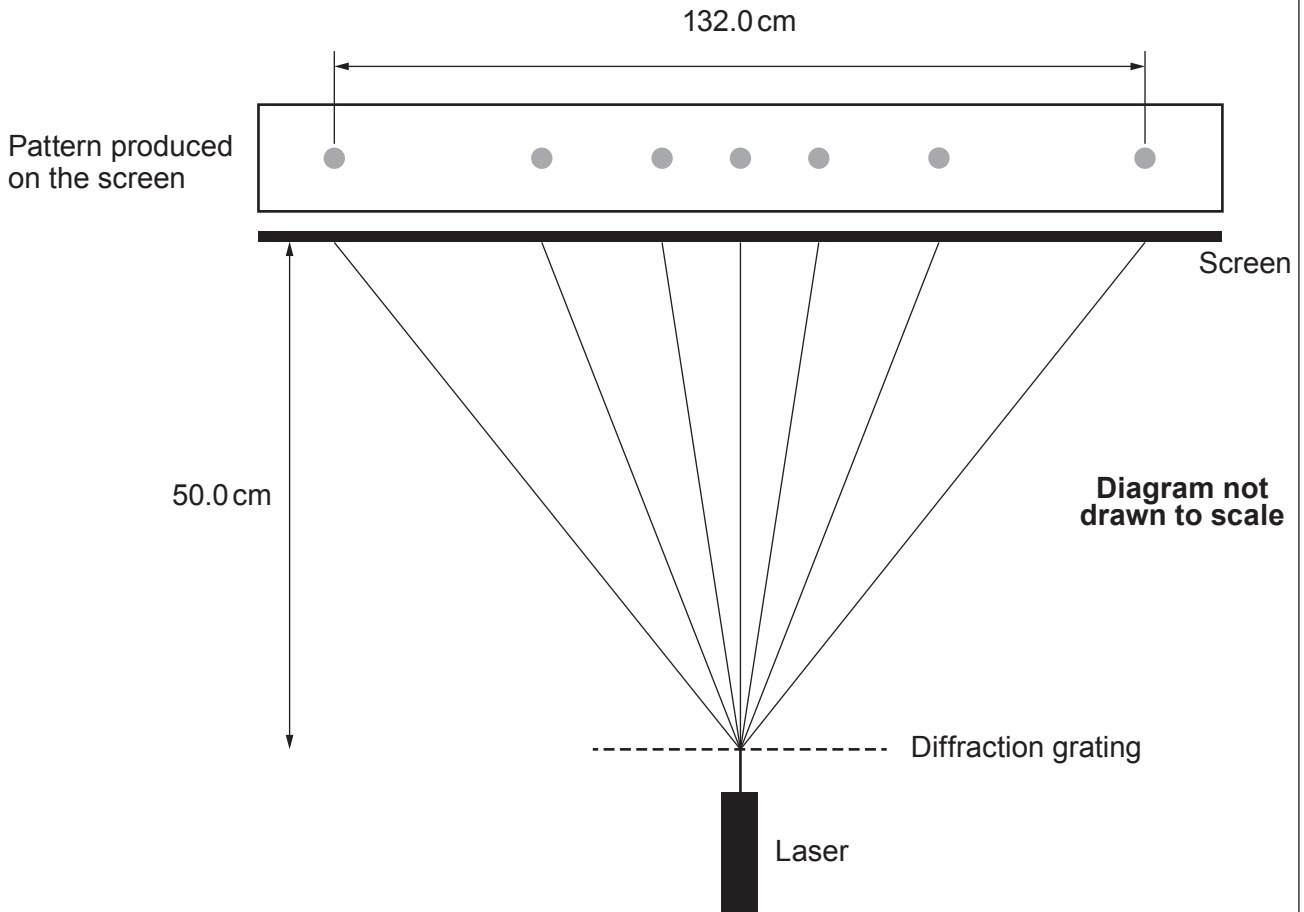

Diagram 2

- (c) Light from a laser is incident normally on a diffraction grating with 500 lines per millimetre. The diagram shows the apparatus and the observed pattern on the screen. The distance along the screen between the **third** order maxima is measured to be 132.0 cm. The distance between the diffraction grating and the screen is 50.0 cm.



- (i) Show that the diffraction angle for the third order spot is 53° . [2]

.....

.....

.....

.....

- (ii) Calculate the wavelength of the laser light. [4]

.....

.....

.....

.....

- (d) The diffraction grating is now replaced with a double slit. Calculate the wavelength of laser light from this set-up using the information given on the diagram. [4]

Examiner
only

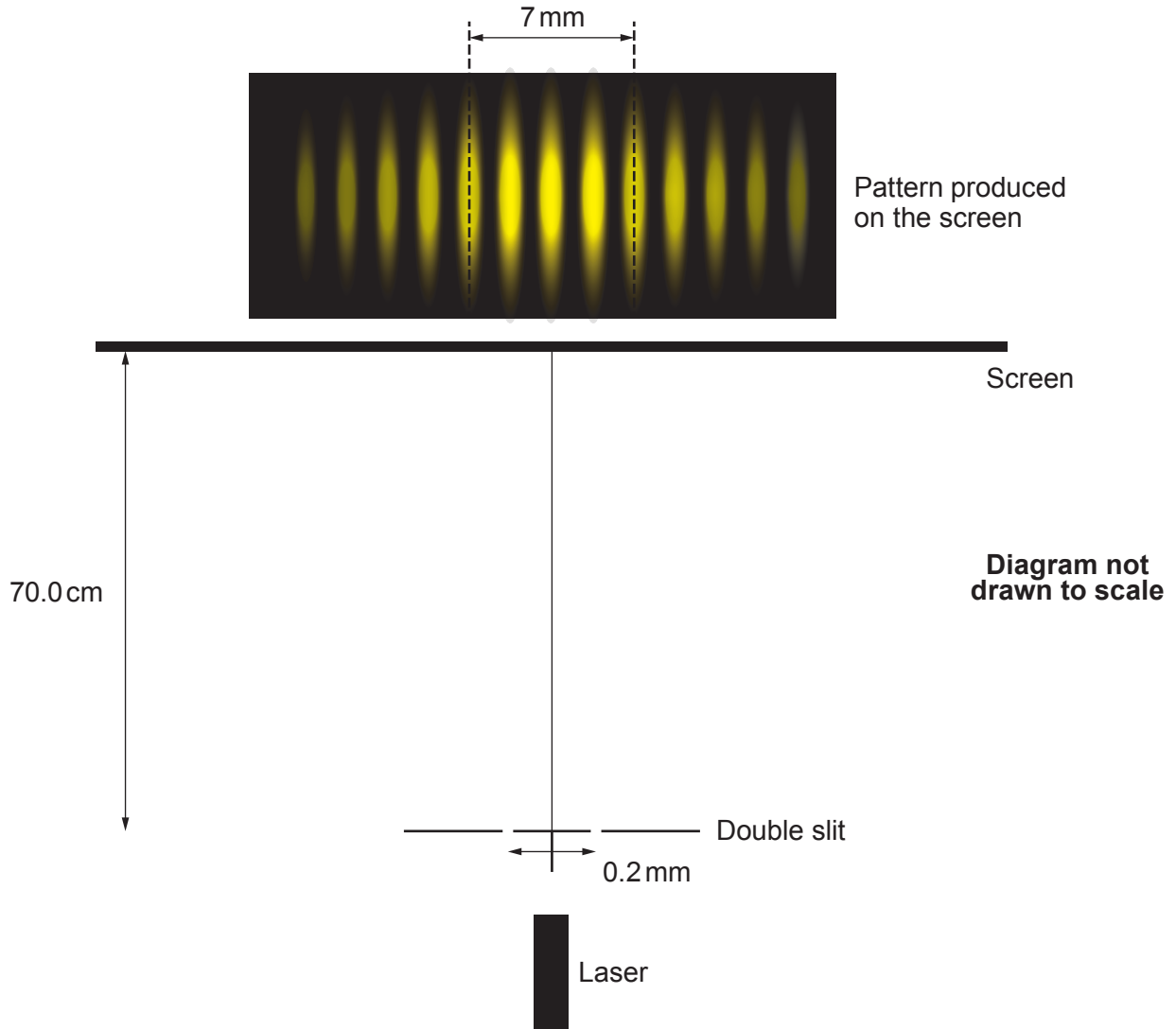

.....

.....

.....

.....

.....

.....

.....

.....

- (e) In the methods of parts (c) and (d), the slit separation and the number of lines per mm are measured precisely by the manufacturers and have negligible uncertainty. All other distances are measured with a metre ruler that has a resolution of ± 1 mm. Explain why the method using a diffraction grating gives a smaller uncertainty in the laser wavelength than using a double slit. [3]

.....

.....

.....

.....

.....

.....

.....

.....

17

3. (a) There is an electric current of 0.16 A in a filament lamp. Calculate the charge that passes through the lamp in 15 minutes. [2]

.....

.....

.....

- (b) (i) Define the unit of potential difference, the volt. [1]

.....

.....

.....

- (ii) Calculate the energy converted by the lamp in part (a) if the potential difference across it is 6.0 V . [2]

.....

.....

.....

.....

- (c) (i) Louis, a Physics student, sets up a circuit to investigate how current varies with potential difference for an unknown electrical component. **Complete** the following circuit diagram of the apparatus that he should use. [2]

Variable power supply

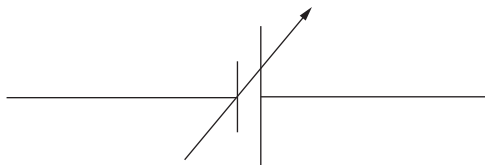

Unknown component

4. (a) Catherine uses a diffraction grating to observe the first order emission spectrum from a lamp containing gas atoms. Describe what she observes. [2]

.....

.....

.....

- (b) Determine from the following energy level diagrams whether a photon of wavelength 565 nm is created from either sodium or cadmium atoms or both. [4]



.....

.....

.....

.....

.....

.....

.....

.....

- (c) Explain why a **population inversion**, **metastable state** and **stimulated emission** are required for a laser to work. [4]

.....

.....

.....

.....

.....

.....

.....

.....

.....

.....

- (d) A stationary barium-137 nucleus emits a gamma ray photon of frequency 1.61×10^{20} Hz.

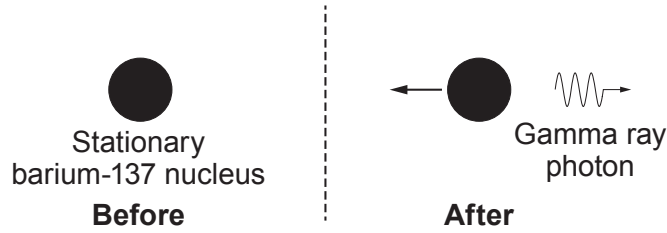

- (i) Show that the momentum of the gamma ray photon is $3.56 \times 10^{-22} \text{ kg m s}^{-1}$. [2]

.....

.....

.....

- (ii) Calculate the final speed of the barium-137 nucleus if the mass of the barium is 2.29×10^{-25} kg. Give your reasoning. [3]

.....

.....

.....

.....

.....

- (iii) Calculate the total energy released in this emission. [3]

.....

.....

.....

.....

.....

- (e) Evaluate the benefits for scientists and engineers of determining the value of physical constants such as the Planck constant and numbers such as π to a high degree of accuracy. [2]

.....

.....

.....

.....

.....

5. Stephan sets up the following circuit to determine the resistance of a resistor, X.

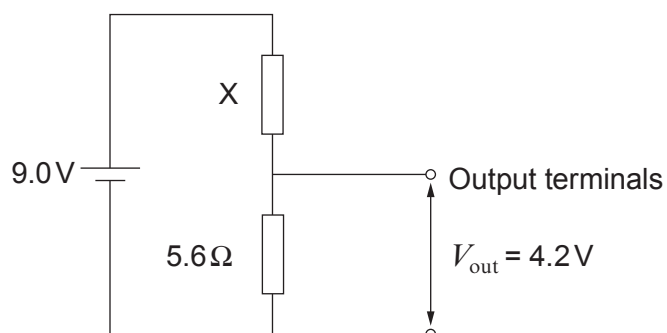

- (a) Show that the resistance of X is approximately $6\ \Omega$ assuming that the supply has negligible resistance.

[4]

.....

.....

.....

.....

.....

- (b) Stephan connects an external indicator circuit that has an overall resistance value of $12.0\ \Omega$ as shown below. Calculate the new potential difference between the output terminals.

[5]

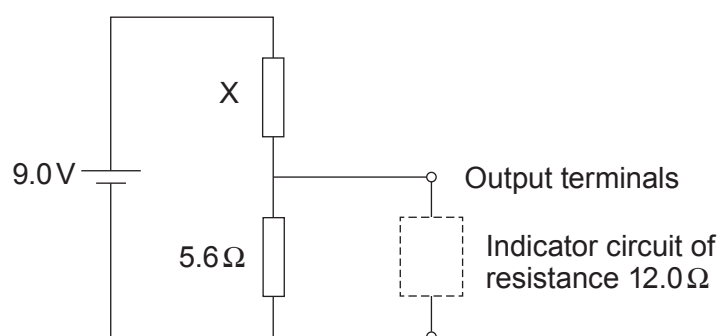

.....

.....

.....

.....

.....

.....

.....

- (c) Bruno suggests that Stephan replaces resistor X with a thermistor that changes its resistance from $10\text{ k}\Omega$ at 0°C to $8.7\text{ k}\Omega$ at 30°C . Explain why the circuit cannot be used as a temperature sensor if the indicator circuit requires a minimum current of 10 mA to operate. [2]

.....

.....

.....

.....

.....

- (d) Explain why superconductors cannot be used as temperature sensors at very low temperatures. [1]

.....

.....

.....

END OF PAPER

12

BLANK PAGE

BLANK PAGE