

Please check the examination details below before entering your candidate information

Candidate surname

Other names

Centre Number

Candidate Number

Pearson Edexcel
Level 1/Level 2 GCSE (9–1)

--	--	--	--	--

--	--	--	--	--

Friday 14 June 2019

Morning (Time: 1 hour 45 minutes)

Paper Reference **1PH0/2H**

Physics
Paper 2

Higher Tier

You must have:
Calculator, ruler

Total Marks

Instructions

- Use **black** ink or ball-point pen.
- **Fill in the boxes** at the top of this page with your name, centre number and candidate number.
- Answer **all** questions.
- Answer the questions in the spaces provided
– *there may be more space than you need.*
- Calculators may be used.
- Any diagrams may NOT be accurately drawn, unless otherwise indicated.
- You must **show all your working out** with **your answer clearly identified** at the **end of your solution**.

Information

- The total mark for this paper is 100.
- The marks for **each** question are shown in brackets
– *use this as a guide as to how much time to spend on each question.*
- In questions marked with an **asterisk (*)**, marks will be awarded for your ability to structure your answer logically showing how the points that you make are related or follow on from each other where appropriate.
- A list of equations is included at the end of this exam paper.

Advice

- Read each question carefully before you start to answer it.
- Try to answer every question.
- Check your answers if you have time at the end.

Turn over ►

P56434A

©2019 Pearson Education Ltd.
1/1/1/1/1/1/



Pearson

Answer ALL questions. Write your answers in the spaces provided.

Some questions must be answered with a cross in a box .
If you change your mind about an answer, put a line through the box and then mark your new answer with a cross .

1 (a) Figure 1 shows a paint sprayer.

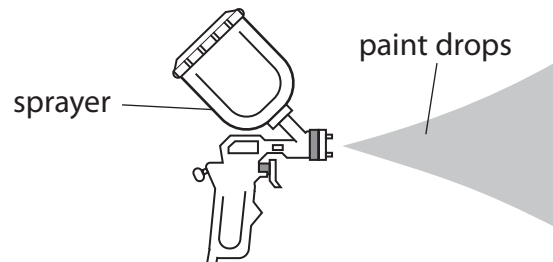

Figure 1

Some paint sprayers give the paint drops a positive charge as they leave the sprayer.

(i) The paint drops have a positive charge because the sprayer

(1)

- A removes electrons from the paint drops
- B adds electrons to the paint drops
- C removes protons from the paint drops
- D adds protons to the paint drops

(ii) Figure 2 shows the spray pattern from two different paint sprayers.



Figure 2

Sprayer X does not charge the paint drops. Sprayer Y gives the paint drops a positive charge.

Explain how charging the paint drops changes the shape of the spray pattern.

(2)

.....

.....

.....

.....



(iii) Sprayer Y is used in a factory to paint a metal object.

The object hangs by a metal wire that is connected to earth.

Explain why a metal wire is used to connect the object to earth.

(2)

.....

.....

.....

.....

(b) Figure 3 shows two charged metal plates.

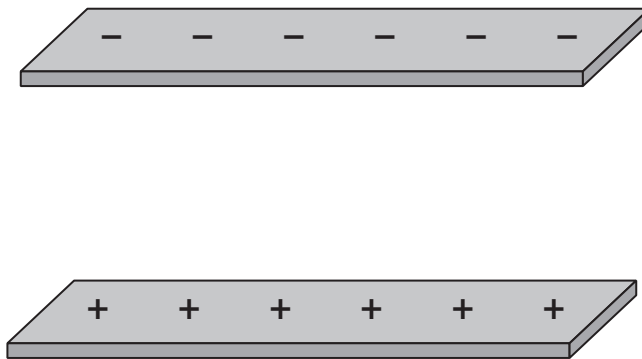

Figure 3

The top plate has a negative electric charge.

The bottom plate has a positive electric charge.

On Figure 3, draw the electric field lines between the two plates and show the direction of this electric field.

(2)

(Total for Question 1 = 7 marks)

.....

.....

.....

.....



2 (a) Which of these is the equation for work done?

(1)

- A work done = force \div distance moved in direction of force
- B work done = force \times distance moved in direction of force
- C work done = force \div distance moved at right angles to direction of force
- D work done = force \times distance moved at right angles to direction of force

(b) A ball has a mass of 0.046 kg.

(i) Calculate the change in gravitational potential energy when the ball is lifted through a vertical height of 2.05 m.

Use the equation

$$\Delta GPE = m \times g \times \Delta h$$

(2)

change in gravitational potential energy = J

(ii) The ball is released.

Calculate the kinetic energy of the ball when the speed of the ball is 3.5 m/s.

(3)

kinetic energy of the ball = J

DO NOT WRITE IN THIS AREA

DO NOT WRITE IN THIS AREA

DO NOT WRITE IN THIS AREA

DO NOT WRITE IN THIS AREA

DO NOT WRITE IN THIS AREA

DO NOT WRITE IN THIS AREA



(iii) The ball bounces several times.

Figure 4 shows how the height of the ball above the floor changes with time.

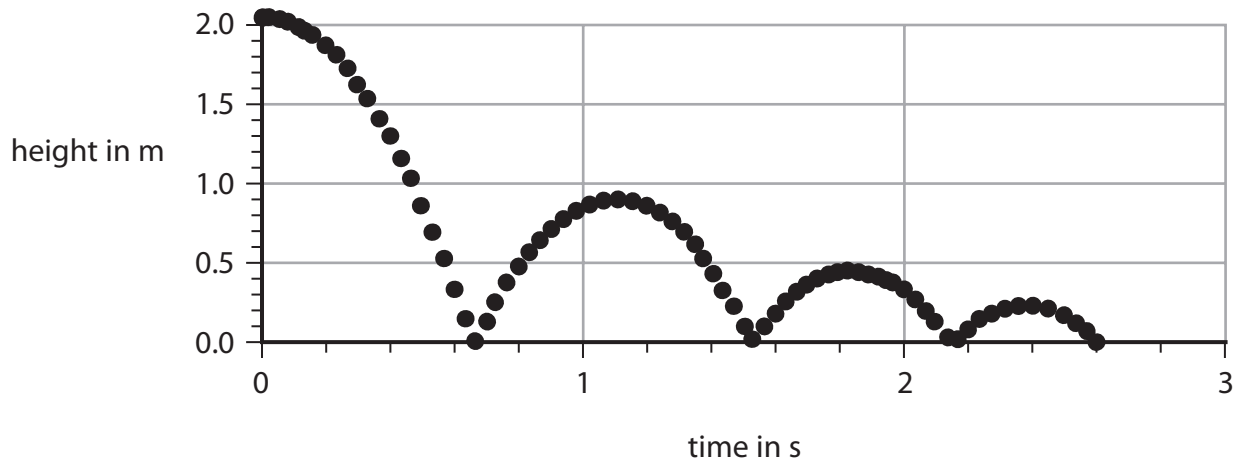

Figure 4

Use Figure 4 to estimate the maximum height that the ball reaches after the first bounce.

(1)

height after first bounce = m

(iv) Explain why the ball does not bounce back to its starting height of 2.05 m.

(2)

.....

.....

.....

.....

(Total for Question 2 = 9 marks)



3 (a) Which of these symbols is used to represent a thermistor in an electrical circuit? (1)

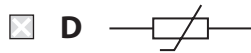
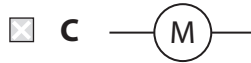
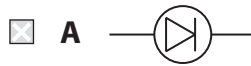

(b) A student investigates how the current in a lamp changes with the potential difference across the lamp.

The student uses the results to calculate the resistance of the lamp.

The results are shown in the table in Figure 5.

potential difference in V	current in A	resistance in Ω
1.0	0.09	11
2.0	0.14	14
3.0	0.18	17
4.0	0.22	18
5.0	0.26	
6.0	0.30	20

Figure 5

(i) One value of resistance is missing from the table in Figure 5.

Calculate the value of resistance that is missing from the table.

(3)

missing resistance = Ω



(ii) The student writes this conclusion:

'The resistance of the lamp is directly proportional to the potential difference.'

Comment on the student's conclusion.
Use information from Figure 5 in your answer.

(3)

(iii) The student used a power supply that had fixed output voltage settings.
Each of these outputs was a whole number of volts.

Describe how the student could add a component to the circuit that would provide a continuously variable voltage across the lamp.

(2)

(Total for Question 3 = 9 marks)

DO NOT WRITE IN THIS AREA

DO NOT WRITE IN THIS AREA

DO NOT WRITE IN THIS AREA

DO NOT WRITE IN THIS AREA

DO NOT WRITE IN THIS AREA

DO NOT WRITE IN THIS AREA



P 5 6 4 3 4 A 0 7 3 2

4 (a) Figure 6 shows four forces, P, Q, R and S, acting on a rod.
The rod can rotate around an axle.

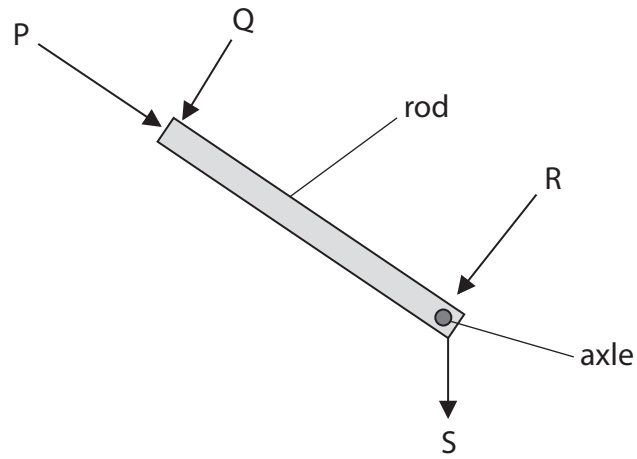

Figure 6

Which force will make the rod rotate about the axle?

(1)

- A P
- B Q
- C R
- D S

DO NOT WRITE IN THIS AREA

DO NOT WRITE IN THIS AREA

DO NOT WRITE IN THIS AREA

DO NOT WRITE IN THIS AREA

DO NOT WRITE IN THIS AREA

DO NOT WRITE IN THIS AREA



(b) Figure 7 shows a person trying to lift a large rock using a metal bar.

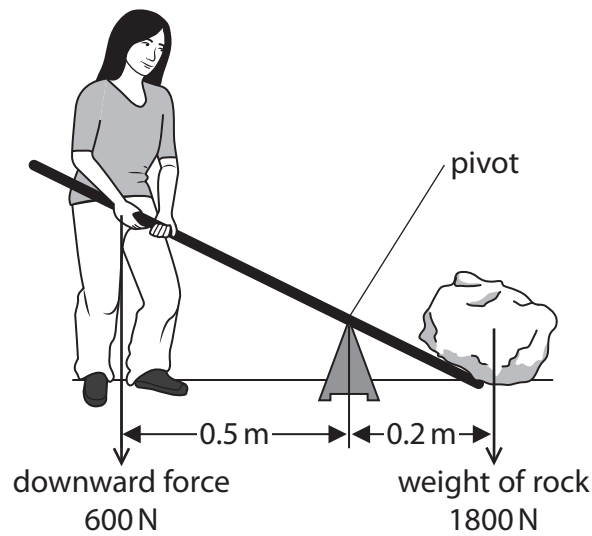

Figure 7

The rock weighs 1800 N.

The person can only produce a downwards force of 600 N.

The person cannot lift the rock.

(i) Explain, using calculations, why the person cannot lift the rock.

(3)

.....

.....

.....

.....

.....

.....

.....

(ii) Explain **one** change to the arrangement that will make it possible for this person to lift the rock.

(2)

.....

.....

.....

.....



(c) Figure 8 shows a bicycle.

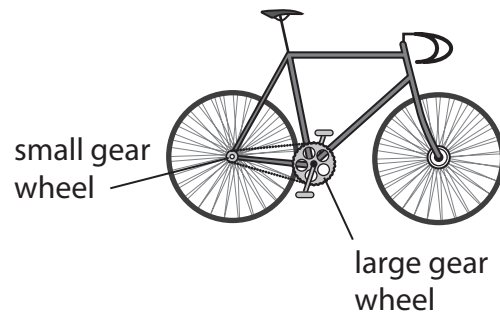

Figure 8

- (i) The rider uses the pedals to make the large gear wheel turn.

The large gear wheel moves the chain.
The chain turns the small gear wheel.

The large gear wheel has 48 teeth.

The small gear wheel has 12 teeth.

The large gear wheel turns 2 times each second.

Calculate the number of times that the small gear wheel turns each second.

(2)

..... turns each second

DO NOT WRITE IN THIS AREA

DO NOT WRITE IN THIS AREA

DO NOT WRITE IN THIS AREA

DO NOT WRITE IN THIS AREA

DO NOT WRITE IN THIS AREA

DO NOT WRITE IN THIS AREA



(ii) Oil is applied to the wheel of a bicycle at the point shown in Figure 9.

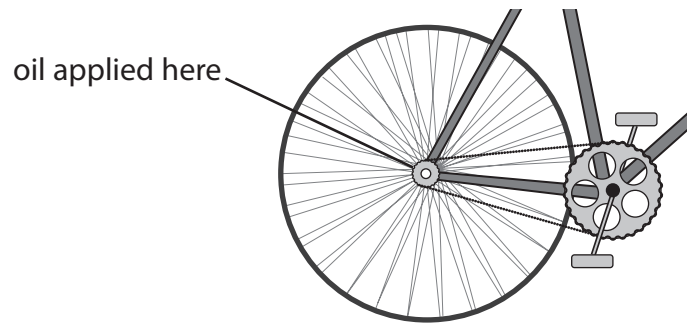

Figure 9

Explain how the oil improves the efficiency of the bicycle.

(3)

.....

.....

.....

.....

.....

.....

(Total for Question 4 = 11 marks)



- 5 (a) A student uses a plotting compass to investigate the magnetic field around a wire.

Figure 10 shows the wire going straight through a card.

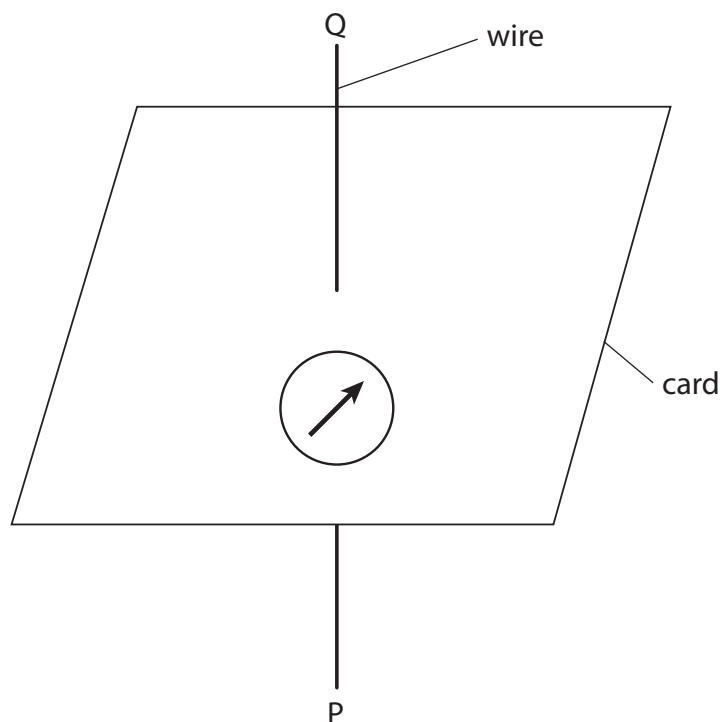
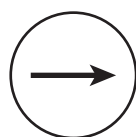

Figure 10

Figure 10 shows the compass needle when there is no current in the wire.

- (i) Which of these shows a possible direction of the compass needle when there is a current in the wire going from P to Q?

(1)



A



B

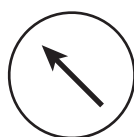

C

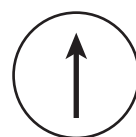

D



(ii) Describe how the student could develop the investigation to find the shape of the magnetic field produced by the current.

(3)

.....

.....

.....

.....

.....

.....

DO NOT WRITE IN THIS AREA

DO NOT WRITE IN THIS AREA

DO NOT WRITE IN THIS AREA

DO NOT WRITE IN THIS AREA

DO NOT WRITE IN THIS AREA

DO NOT WRITE IN THIS AREA



(b) Figure 11 shows a copper wire between two magnetic poles.

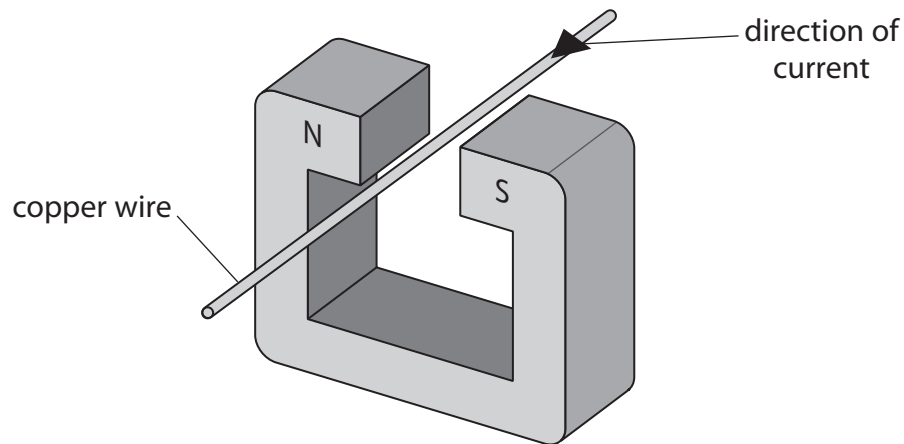

Figure 11

The current in the wire is in the direction shown by the arrow.

The wire experiences a force due to the magnetic field.

(i) The direction of the force due to the magnetic field is

(1)

- A** down
- B** up
- C** towards the north pole of the magnet
- D** towards the south pole of the magnet

(ii) The interaction between the magnetic fields produced by the magnet and the current in the wire produces forces on the magnet and the wire.

Compare these two forces.

(1)

.....
.....

DO NOT WRITE IN THIS AREA

DO NOT WRITE IN THIS AREA

DO NOT WRITE IN THIS AREA

DO NOT WRITE IN THIS AREA

DO NOT WRITE IN THIS AREA

DO NOT WRITE IN THIS AREA



(iii) Figure 12 shows a different wire inside a uniform magnetic field.

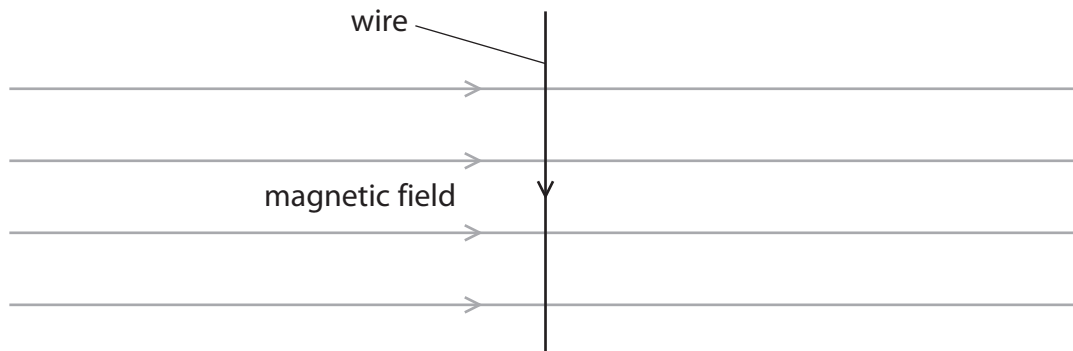

Figure 12

The magnetic flux density of the magnetic field is 0.72 N/A m .

The length of the wire inside the field is 30 mm .

The size of the force due to the magnetic field on the wire is 0.045 N .

Calculate the size of the current in the wire.

Use an equation selected from the list of equations at the end of this paper.

(3)

current in the wire = A

(Total for Question 5 = 9 marks)



6 (a) A teacher is demonstrating electromagnetic induction.
The teacher has a bar magnet, a coil of wire and a sensitive voltmeter.

(i) Draw a diagram to show how the teacher should arrange the apparatus.

(1)

(ii) Explain how the teacher could use this apparatus to demonstrate the factors affecting the size and direction of the induced potential difference.

(4)

.....

.....

.....

.....

.....

.....

.....

.....

DO NOT WRITE IN THIS AREA

DO NOT WRITE IN THIS AREA

DO NOT WRITE IN THIS AREA

DO NOT WRITE IN THIS AREA

DO NOT WRITE IN THIS AREA

DO NOT WRITE IN THIS AREA



(b) There is a changing magnetic field in the core of a transformer.

(i) Describe the cause of the changing magnetic field in the core of the transformer.

(2)

.....

.....

.....

.....

(ii) A potential difference of 230V is applied across the primary coil of a transformer. There is a potential difference of 15V across the secondary coil. The primary coil has 2000 turns.

Calculate the number of turns in the secondary coil.

Use an equation selected from the list of equations at the end of this paper.

(3)

..... turns

(Total for Question 6 = 10 marks)

DO NOT WRITE IN THIS AREA

DO NOT WRITE IN THIS AREA

DO NOT WRITE IN THIS AREA

DO NOT WRITE IN THIS AREA

DO NOT WRITE IN THIS AREA

DO NOT WRITE IN THIS AREA



7 (a) A student measures the density of glass.

The student has

- a bag of marbles, all made from the same type of glass
- a weighing balance
- a plastic measuring cylinder containing water

Describe how the student could find, as accurately as possible, the density of the glass used for the marbles.

(4)

.....

.....

.....

.....

.....

.....

.....

.....

.....

(b) A beaker contains 0.25 kg of water at room temperature.
The beaker of water is heated until the water reaches boiling point (100 °C).
The specific heat capacity of water is 4200 J/kg °C.
The total amount of thermal energy supplied to the water is 84 000 J.

(i) Calculate the temperature of the water before it was heated.

Use an equation selected from the list of equations at the end of this paper.

(3)

temperature before heating = °C

DO NOT WRITE IN THIS AREA

DO NOT WRITE IN THIS AREA

DO NOT WRITE IN THIS AREA

DO NOT WRITE IN THIS AREA

DO NOT WRITE IN THIS AREA

DO NOT WRITE IN THIS AREA



- (ii) The heating continues until 0.15 kg of the water has turned into steam.
The thermal energy needed to turn the boiling water into steam is 0.34 MJ.

Calculate the specific latent heat of vapourisation of water.

Use an equation selected from the list of equations at the end of this paper.

(2)

specific latent heat = MJ/kg

- (iii) The graph in Figure 13 shows how the **volume** of 1 kg of water changes with temperature.

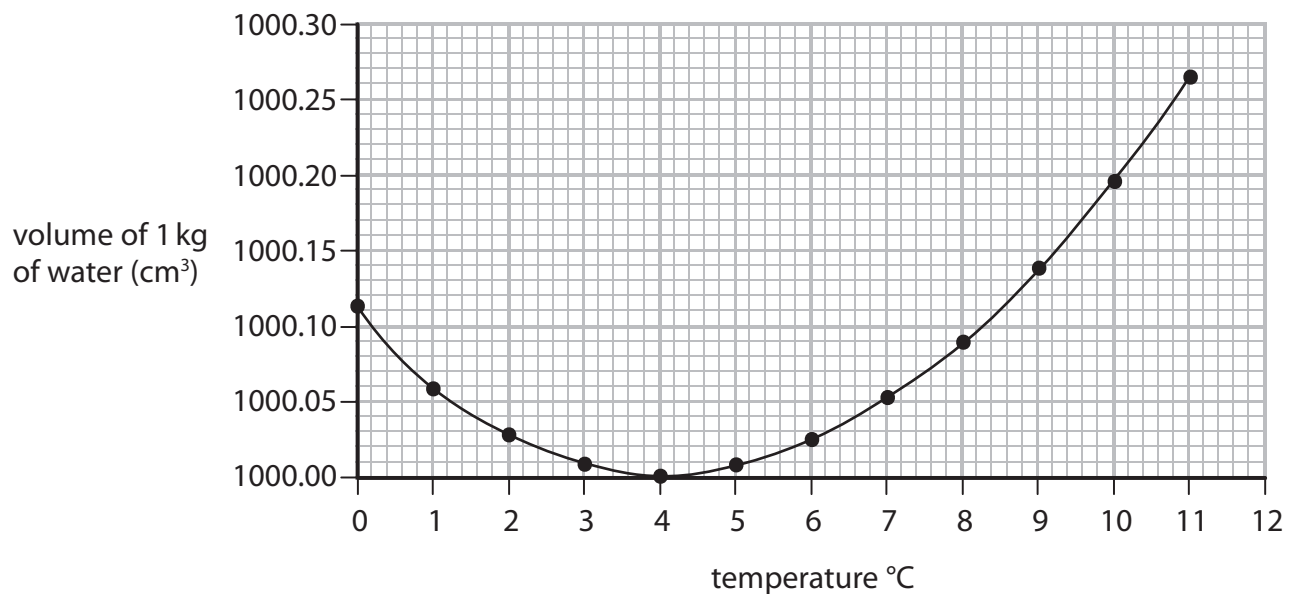

Figure 13

Describe how the **density** of water changes with temperature over the range of temperature shown in Figure 13.

Calculations are not required.

(2)

.....

.....

.....

.....

(Total for Question 7 = 11 marks)



8 (a) Figure 14 shows an athlete using a fitness device.

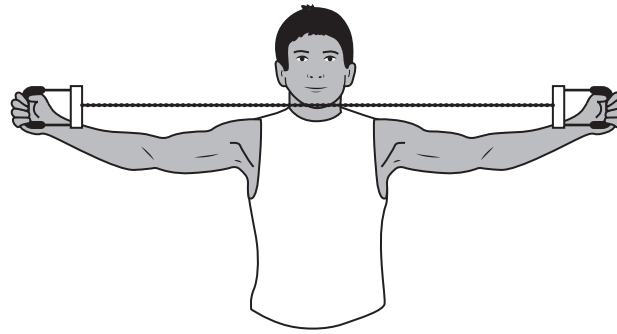

Figure 14

The athlete stretches the spring in the device by pulling the handles apart.

The spring constant of the spring is 140 N/m .

The athlete does 45 J of work to extend the spring.

The athlete takes 0.6 s to expand the spring.

(i) Calculate the useful power output of the athlete when stretching the spring. (2)

useful power output of the athlete = W

(ii) Calculate the extension of the spring. (3)
Use an equation selected from the list of equations at the end of this paper.

extension of the spring = m

DO NOT WRITE IN THIS AREA

DO NOT WRITE IN THIS AREA

DO NOT WRITE IN THIS AREA

DO NOT WRITE IN THIS AREA

DO NOT WRITE IN THIS AREA

DO NOT WRITE IN THIS AREA



(b) A student investigates the stretching of a long piece of rubber.

Figure 15 shows the apparatus to be used.

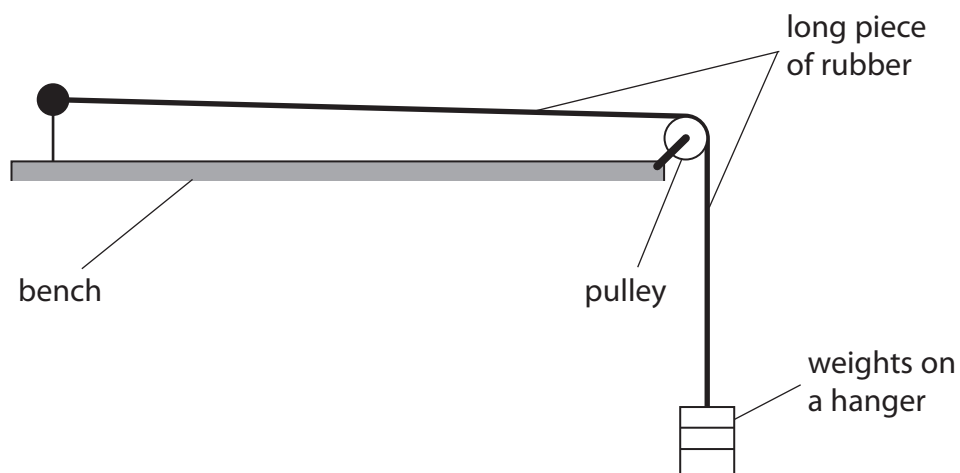

Figure 15

The student puts just enough weight on the weight hanger to make the piece of rubber just tight.

The student wants to plot a graph to show how the extension of the piece of rubber varies with the force used to stretch it.

The student adds a known weight to the weight hanger.

- (i) Describe how the student could measure the extension of the rubber when he adds another weight to the weight hanger.

(2)

.....

.....

.....

.....



- (ii) The student obtains a series of values of force and extension while loading the piece of rubber and then unloading it.

Figure 16 shows the graph of the student's values.

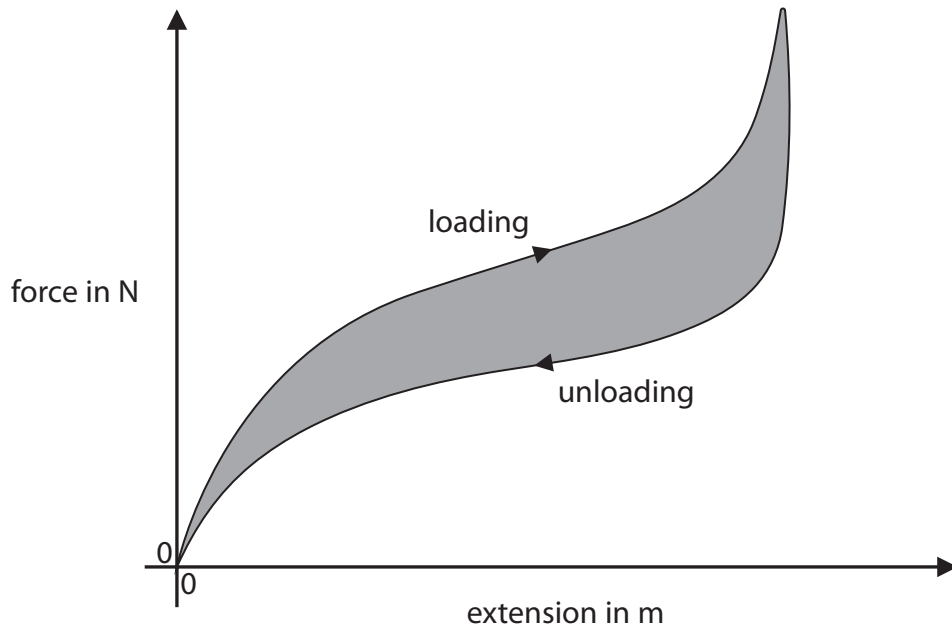

Figure 16

Explain how the shape of this graph shows that the distortion of the piece of rubber being stretched is different from the distortion of a spring being stretched.

(2)

.....

.....

.....

.....

- (c) The area between the curve and the extension axis of a force/extension graph corresponds to work done or energy transferred.

Suggest what the shaded area of the graph in Figure 16 represents.

(2)

.....

.....

.....

.....

(Total for Question 8 = 11 marks)



DO NOT WRITE IN THIS AREA

DO NOT WRITE IN THIS AREA

DO NOT WRITE IN THIS AREA

DO NOT WRITE IN THIS AREA

DO NOT WRITE IN THIS AREA

DO NOT WRITE IN THIS AREA

BLANK PAGE



- 9 Figure 17 shows a crane lifting a concrete block from the bottom of a deep pool of water. The top of the block is a distance, h , below the surface of the water.

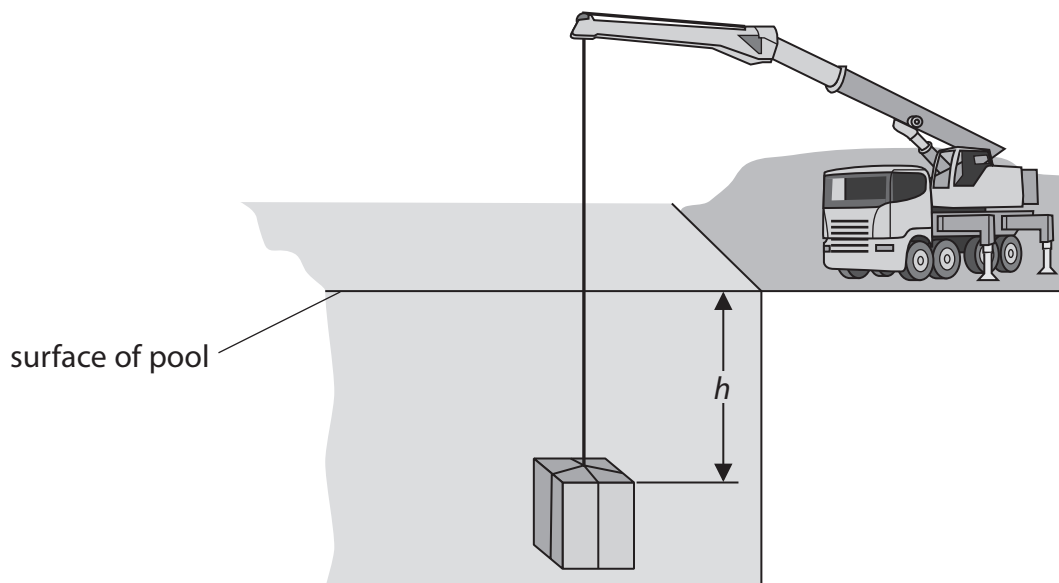

Figure 17

- (a) The force on the top of the block due to the water above it is 41 000 N.

The pressure due to the water on the top surface of the block is 66 000 Pa.

- (i) Calculate the area of the top surface of the block.

(2)

area of the top surface of the block = m²

- (ii) The density of water is 1000 kg/m³.

Calculate the distance, h , between the top of the block and the surface of the water.

Gravitational field strength, g , is 10 N/kg.

Use an equation selected from the list of equations at the end of this paper.

(2)

$h =$ m



DO NOT WRITE IN THIS AREA

DO NOT WRITE IN THIS AREA

DO NOT WRITE IN THIS AREA

DO NOT WRITE IN THIS AREA

DO NOT WRITE IN THIS AREA

DO NOT WRITE IN THIS AREA

(iii) Explain why there is an upthrust produced by the water on the block.

(2)

.....

.....

.....

.....

DO NOT WRITE IN THIS AREA

DO NOT WRITE IN THIS AREA

DO NOT WRITE IN THIS AREA

DO NOT WRITE IN THIS AREA

DO NOT WRITE IN THIS AREA

DO NOT WRITE IN THIS AREA



P 5 6 4 3 4 A 0 2 5 3 2

*(iv) The crane raises the block until it is high enough out of the water to be loaded on to a lorry.

The block moves upwards at a constant speed even though the lifting force in the cable changes.

Figure 18 shows the graph of how the lifting force changes while the block is being raised.

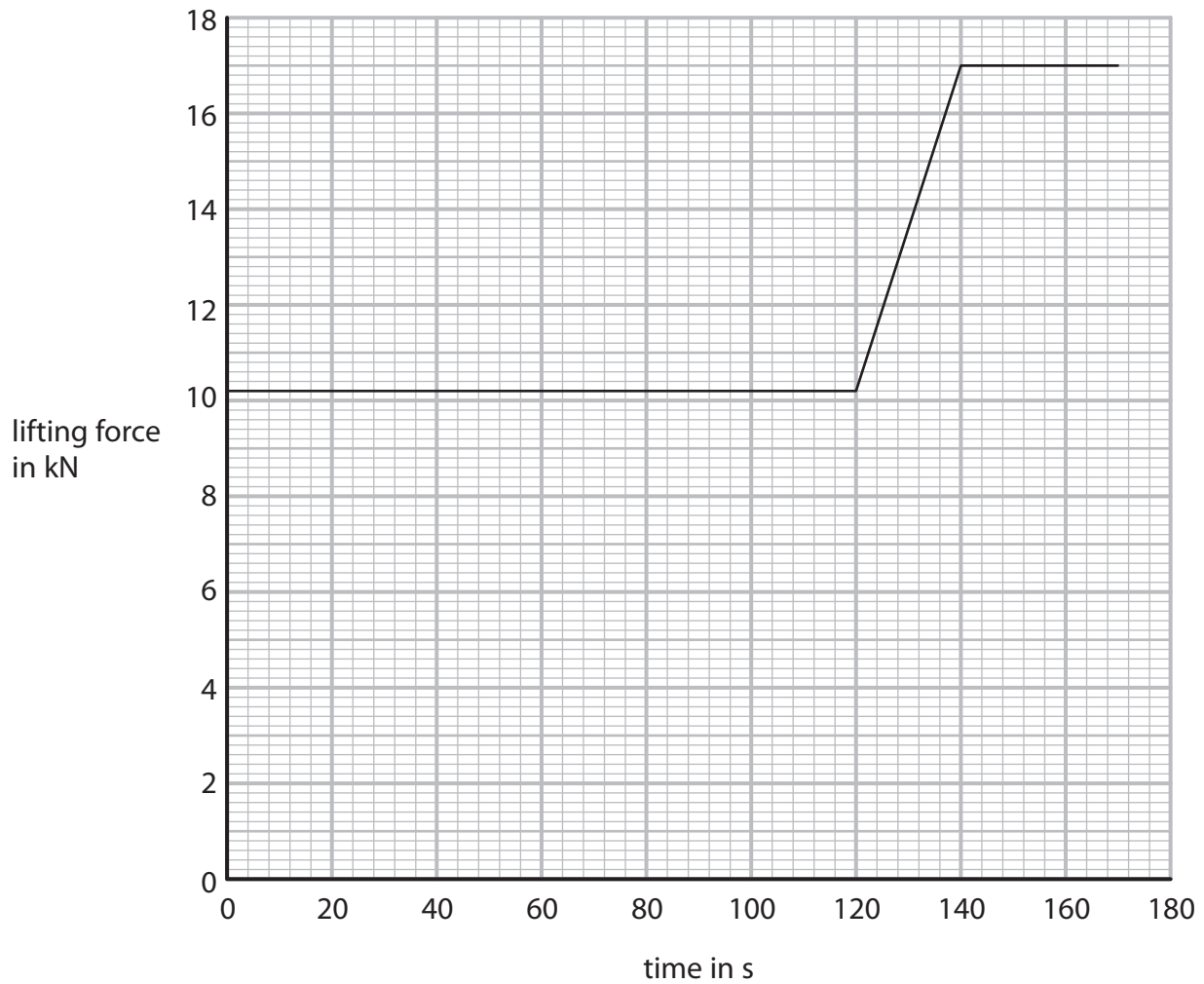

Figure 18

DO NOT WRITE IN THIS AREA

DO NOT WRITE IN THIS AREA

DO NOT WRITE IN THIS AREA

DO NOT WRITE IN THIS AREA

DO NOT WRITE IN THIS AREA

DO NOT WRITE IN THIS AREA



Explain why the lifting force changes as shown on the graph in Figure 18.
Include calculation(s) in your answer.

(6)

DO NOT WRITE IN THIS AREA

DO NOT WRITE IN THIS AREA

DO NOT WRITE IN THIS AREA

DO NOT WRITE IN THIS AREA

DO NOT WRITE IN THIS AREA

DO NOT WRITE IN THIS AREA

(Total for Question 9 = 12 marks)



10 (a) Figure 19 shows two electrical devices for heating water.

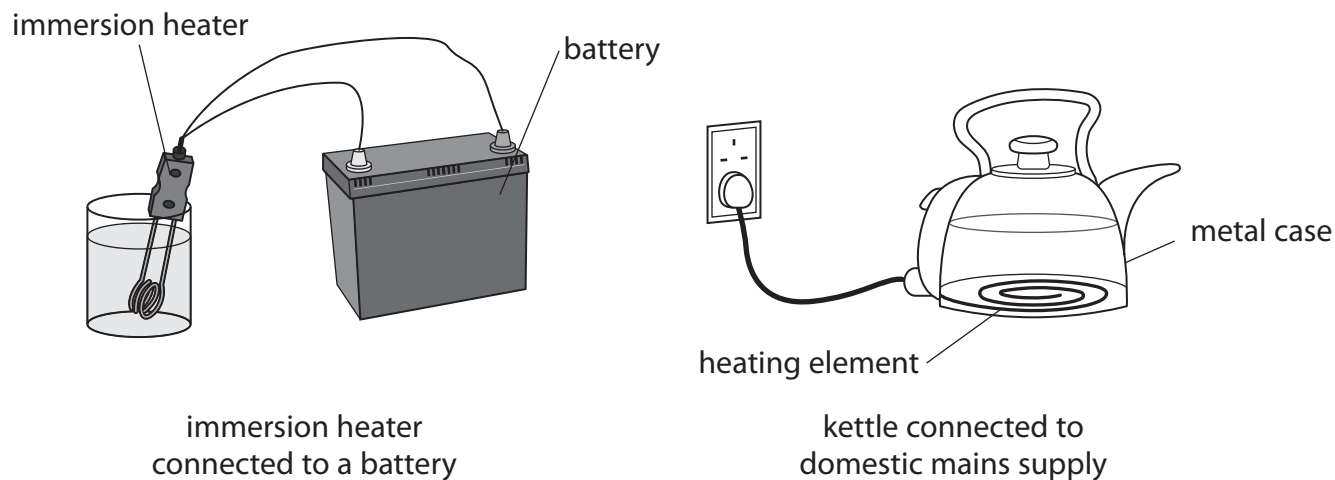

Figure 19

(i) The current in the element of the immersion heater is 14 A.

The power of the immersion heater is 130 W.

Calculate the resistance of the immersion heater.

Give your answer to two significant figures.

(3)

resistance of immersion heater = Ω

(ii) The current in the heating element of the kettle is 8.3 A.

State **two** differences between the movement of charge in the heating element of the kettle and the movement of charge in the immersion heater.

(2)

1

2

DO NOT WRITE IN THIS AREA

DO NOT WRITE IN THIS AREA

DO NOT WRITE IN THIS AREA

DO NOT WRITE IN THIS AREA

DO NOT WRITE IN THIS AREA

DO NOT WRITE IN THIS AREA



*(b) Figure 20 shows the three-pin plug used to connect the kettle to the mains.

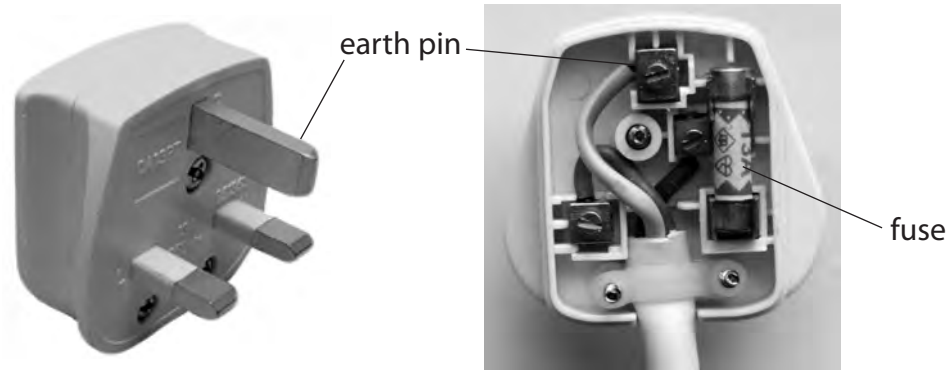

Figure 20

A fault occurs in the kettle causing the live wire to touch the metal case of the kettle.

Explain how the safety features of the plug operate when this fault occurs.

(6)

.....

.....

.....

.....

.....

.....

.....

.....

.....

.....

.....

.....

.....

.....

.....

.....

.....

.....

.....

.....

.....

.....

(Total for Question 10 = 11 marks)

TOTAL FOR PAPER = 100 MARKS

DO NOT WRITE IN THIS AREA

DO NOT WRITE IN THIS AREA

DO NOT WRITE IN THIS AREA

DO NOT WRITE IN THIS AREA

DO NOT WRITE IN THIS AREA

DO NOT WRITE IN THIS AREA





DO NOT WRITE IN THIS AREA

DO NOT WRITE IN THIS AREA

DO NOT WRITE IN THIS AREA

DO NOT WRITE IN THIS AREA

DO NOT WRITE IN THIS AREA

DO NOT WRITE IN THIS AREA

BLANK PAGE



DO NOT WRITE IN THIS AREA

DO NOT WRITE IN THIS AREA

DO NOT WRITE IN THIS AREA

DO NOT WRITE IN THIS AREA

DO NOT WRITE IN THIS AREA

DO NOT WRITE IN THIS AREA

BLANK PAGE



P 5 6 4 3 4 A 0 3 1 3 2

Equations

(final velocity)² – (initial velocity)² = 2 × acceleration × distance

$$v^2 - u^2 = 2 \times a \times x$$

force = change in momentum ÷ time

$$F = \frac{(mv - mu)}{t}$$

energy transferred = current × potential difference × time

$$E = I \times V \times t$$

force on a conductor at right angles to a magnetic field carrying a current = magnetic flux density × current × length

$$F = B \times I \times l$$

$\frac{\text{voltage across primary coil}}{\text{voltage across secondary coil}} = \frac{\text{number of turns in primary coil}}{\text{number of turns in secondary coil}}$

$$\frac{V_p}{V_s} = \frac{N_p}{N_s}$$

potential difference across primary coil × current in primary coil = potential difference across secondary coil × current in secondary coil

$$V_p \times I_p = V_s \times I_s$$

change in thermal energy = mass × specific heat capacity × change in temperature

$$\Delta Q = m \times c \times \Delta\theta$$

thermal energy for a change of state = mass × specific latent heat

$$Q = m \times L$$

to calculate pressure or volume for gases of fixed mass at constant temperature

$$P_1 V_1 = P_2 V_2$$

energy transferred in stretching = 0.5 × spring constant × (extension)²

$$E = \frac{1}{2} \times k \times x^2$$

pressure due to a column of liquid = height of column × density of liquid × gravitational field strength

$$P = h \times \rho \times g$$

DO NOT WRITE IN THIS AREA

DO NOT WRITE IN THIS AREA

DO NOT WRITE IN THIS AREA

