

GCSE (9–1) Chemistry A (Gateway Science)

J248/03 Paper 3 (Higher Tier)

Sample Question Paper

H

Date – Morning/Afternoon

Time allowed: 1 hour 45 minutes

You must have:

- the Data Sheet

You may use:

- a scientific or graphical calculator
- a ruler



First name

Last name

Centre number

Candidate number

INSTRUCTIONS

- Use black ink. You may use an HB pencil for graphs and diagrams.
- Complete the boxes above with your name, centre number and candidate number.
- Answer **all** the questions.
- Write your answer to each question in the space provided.
- Additional paper may be used if required but you must clearly show your candidate number, centre number and question number(s).
- Do **not** write in the bar codes.

INFORMATION

- The total mark for this paper is **90**.
- The marks for each question are shown in brackets [].
- Quality of extended response will be assessed in questions marked with an asterisk (*).
- This document consists of **28** pages.

SECTION A

Answer **all** the questions.

You should spend a maximum of 30 minutes on this section.

- 1 Tim is separating the colours in a sample of black ink using paper chromatography.
He puts a spot of black ink onto filter paper.
He dips the filter paper into ethanol in a beaker.
What is the name given to **ethanol** in this experiment?

- A gas phase
B mobile phase
C solid phase
D stationary phase

Your answer

[1]

- 2 Look at Tim's chromatogram.

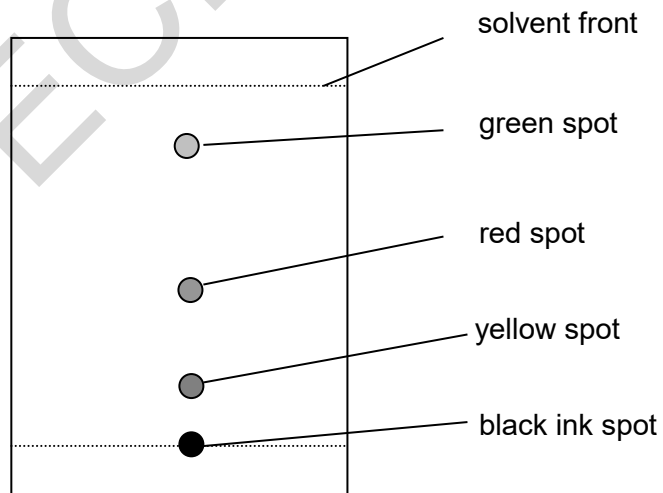

What is the R_f value of the **green** spot? Use a ruler to help you.

- A 0.17
B 0.42
C 0.83
D 1.00

Your answer

[1]

3 What is the best description of the particles in a liquid?

	Distance between particles	Movement of particles
A	close together	in continuous random motion
B	close together	vibrating about a fixed point
C	far apart	in continuous random motion
D	far apart	vibrating about a fixed point

Your answer

[1]

4 The **molecular formula** of decene is $C_{10}H_{20}$.

What is the **empirical formula** of decene?

- A CH_2
- B C_2H_4
- C C_5H_{10}
- D $C_{20}H_{40}$

Your answer

[1]

5 Hardeep does some experiments with acids and alkalis.

He measures the pH of a sample of acid and a sample of alkali.

He adds magnesium metal to a sample of the acid and to a sample of the alkali.

What results should Hardeep expect?

	Results for acid experiments	Results for alkali experiments
A	pH below 7 no reaction with magnesium	pH above 7 magnesium fizzes
B	pH below 7 magnesium fizzes	pH above 7 no reaction with magnesium
C	pH above 7 magnesium fizzes	pH above 7 no reaction with magnesium
D	pH above 7 no reaction with magnesium	pH below 7 magnesium fizzes

Your answer

[1]

6 Rosa tests some compounds to find out if they conduct electricity.

Which row in the table shows the correct results for each compound?

	Solid ionic compound	Ionic compound dissolved in water	Molten ionic compound
A	conducts	does not conduct	conducts
B	conducts	conducts	conducts
C	conducts	conducts	does not conduct
D	does not conduct	conducts	conducts

Your answer

[1]

7 What is the approximate size of an atom?

- A 3×10^{-1} metres
- B 3×10^{-5} metres
- C 3×10^{-9} metres
- D 3×10^{-13} metres

Your answer

[1]

8 During the electrolysis of molten potassium chloride, what is made at the cathode?

- A chlorine
- B hydrogen
- C potassium
- D potassium hydroxide

Your answer

[1]

9 Crude oil can be separated in the laboratory into fractions which have different boiling points.

Look at the table. It shows possible relationships between:

- boiling point
- number of carbon atoms in the molecule
- size of intermolecular forces.

Which letter represents the correct relationship between the boiling point, number of carbon atoms and size of intermolecular forces?

	Boiling point	Number of carbon atoms in the molecule	Size of intermolecular forces
A	high	more than 50	small
B	low	more than 50	large
C	high	less than 20	large
D	low	less than 20	small

Your answer

[1]

10 Which of these shows the balanced symbol equation for the reaction between potassium and chlorine to make potassium chloride?

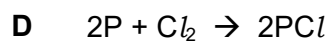
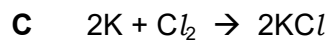
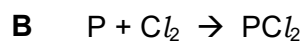
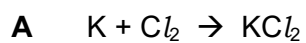

Your answer

[1]

11 Look at the diagrams.

Which diagram shows a solid with the **largest** surface area to volume ratio?

A



B



C



D



Your answer

[1]

12 Ann neutralises nitric acid with potassium hydroxide solution.

Which of these shows the **ionic** equation for neutralisation?

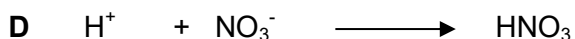
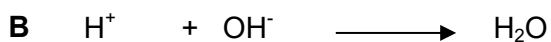
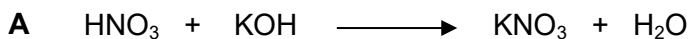

Your answer

[1]

13 A student investigates some acids.

She has a solution of hydrochloric acid of concentration 0.01mol/dm^3 .

This solution has a pH of 2.

She increases the concentration of hydrochloric acid from 0.01mol/dm^3 to 0.1mol/dm^3 .

What is the pH of this new solution?

A 0

B 1

C 3

D 12

Your answer

[1]

14 Which of these is the **best** explanation of what is meant by a strong acid?

A There is a large amount of acid and a small amount of water.

B There is a small amount of acid and a large amount of water.

C The acid is completely ionised in solution in water.

D The acid is partially ionised in solution in water.

Your answer

[1]

15 Look at the diagram.

It shows how the reaction between hydrochloric acid and marble chips (calcium carbonate) can be monitored.

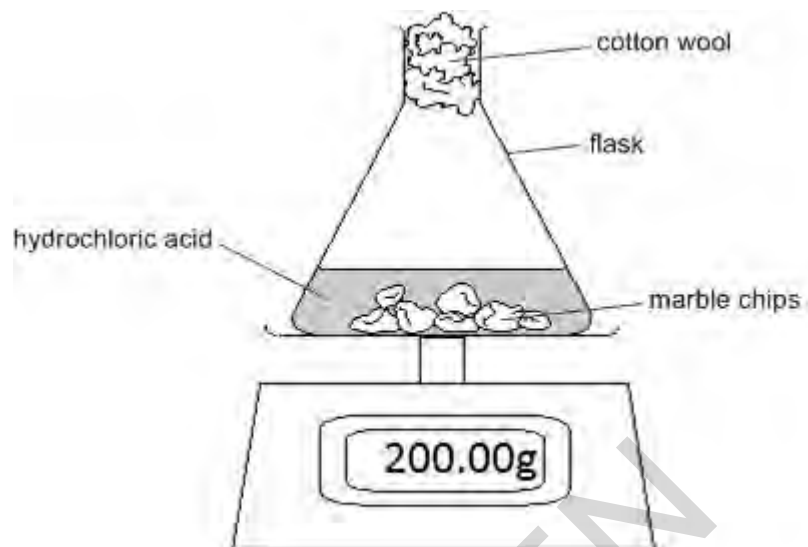

The reading on the balance **decreases** during the reaction.

Which of these statements is the **best** explanation?

- A Acid escapes from the flask.
- B A gas called hydrogen is made which leaves the flask.
- C A gas called carbon dioxide is made which leaves the flask.
- D The temperature in the laboratory changes.

Your answer

[1]

BLANK PAGE

PLEASE TURN OVER FOR THE NEXT QUESTION

SPECIMEN

SECTION B

Answer **all** the questions.

- 16 Look at the table. It shows information about some atoms and ions.

Particle	Atomic number	Mass number	Number of protons	Number of neutrons	Number of electrons	Electronic structure
A	11	23	11	11	2.8.1
B	9	19	9	10	9
C	37	17	17	2.8.7
D	13	27	10	2.8

- (a) Complete the table. [4]

- (b) Particle **A** is a metal **atom**, particle **D** is an **ion**.

Explain why.

.....

.....

..... [2]

- (c) Particle **C** has the electronic structure 2.8.7.

What does this tell you about the position of particle **C** in the Periodic Table?

Explain your answer.

.....

.....

.....

..... [4]

(d) Complete the table below to give information about protons, neutrons and electrons.

	Charge	Mass in atomic mass units
proton	1
neutron
electron	negative

[2]

(e) Rutherford was a scientist who helped to develop the atomic model.

State how Rutherford's work contributed to the development of the atomic model.

.....

[1]

SPECIMEN

- 17 (a) The diagrams show the structures of two forms of carbon.

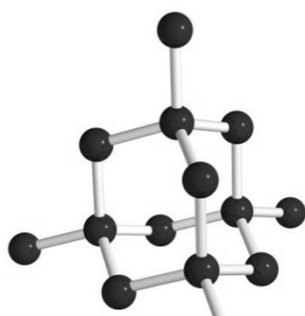

diamond

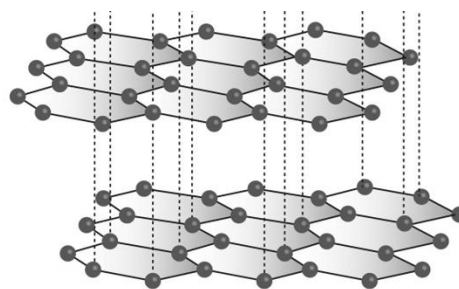

graphite

Graphite is a good conductor of electricity.

Diamond does not conduct electricity.

Use ideas about structure and bonding in diamond and graphite to explain these observations.

.....

.....

.....

[3]

- (b) Carbon can form many thousands of different compounds.

Two examples are shown below.

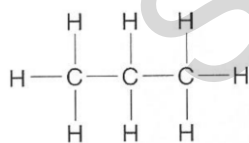

propane

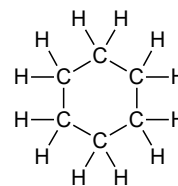

cyclohexane

Why can carbon form many thousands of different compounds?

.....

.....

[1]

(c) Ethanol contains carbon.

Look at some information about ethanol.

Melting point = -114°C

Boiling point = 78°C

Predict the state of ethanol at 25°C . How can you tell?

.....
..... [2]

SPECIMEN

18 Look at the energy profile for a reaction.

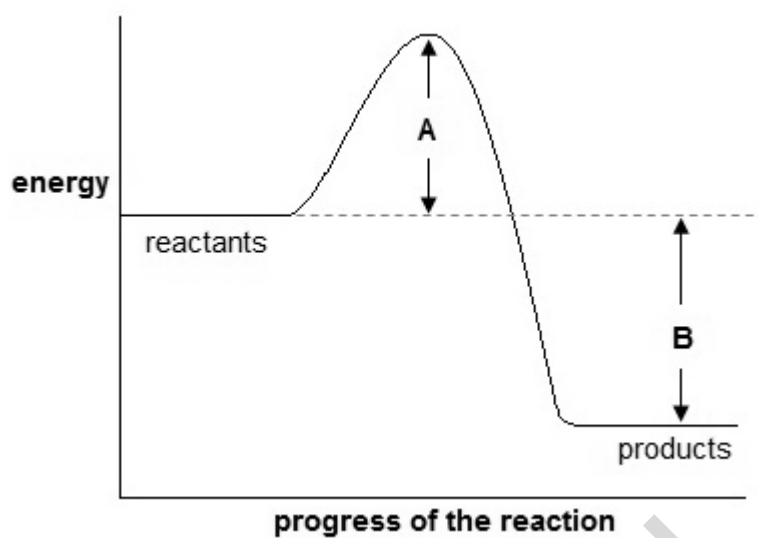

(a) What can you deduce about this reaction?

Include the quantities **A** and **B** and a full explanation.

.....

.....

.....

.....

.....

.....

.....

[4]

(b) Look at the equation.

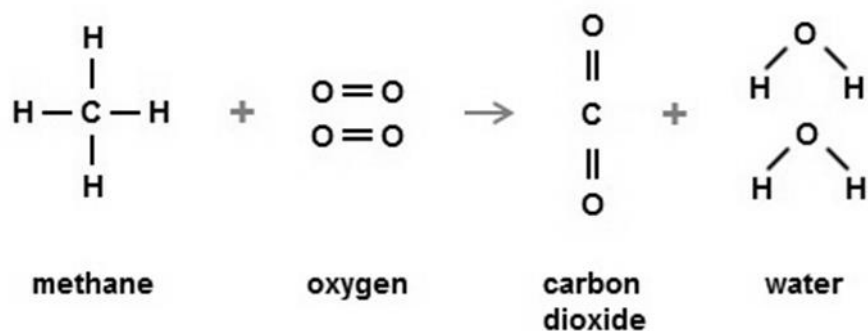

The table shows the bond energies of the bonds involved.

Bond	Bond energy (kJ/mol)
C-H	435
O=O	498
C=O	805
O-H	464

(i) What type of energy change happens when bonds are broken and when bonds are made?

Bonds broken

Bonds made

[2]

(ii) Calculate the energy change for this reaction.

Energy change = kJ/mol

[3]

(c) When propane reacts with oxygen, energy is given out.

Propane gives out 50 kJ/g.

A propane burner is used to boil 200 g of water to make a cup of tea.

The initial temperature of the water is 15°C.

How many grams of propane are needed to heat this water?

Use the following equation:

Energy transferred in J = 4.2 J/g°C x mass of water in g x temperature change in °C

Amount of propane = g

[5]

19 Irenka reacts an element, **X**, with oxygen, O₂.

There is one product. It is the oxide of **X** i.e. **X** oxide.

4.86 g of **X** reacts with 3.20 g of oxygen to make 8.06 g of **X** oxide.

(a) (i) Calculate the number of moles of **X**, oxygen and **X** oxide involved in the reaction.

(The relative atomic mass of **X** is 24.3 and the relative formula mass of oxygen, O₂, is 32.0 and of **X** oxide is 40.3.)

Number of moles of **X** =

Number of moles of O₂ =

Number of moles of **X** oxide =

[3]

(ii) Use your answers to write the **balanced symbol** equation for the reaction between **X** and oxygen to make **X** oxide.

..... [2]

(b) Look at the equation.

It shows the reaction between sodium hydroxide and dilute sulfuric acid.

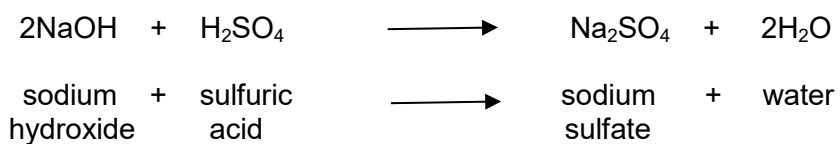

Calculate the mass of sodium hydroxide needed to make 30.0 g of sodium sulfate.

Give your answer to three significant figures.

Mass of sodium hydroxide = g

[3]

SPECIMEN

20 A student is separating a mixture of three substances, **A**, **B** and **C**.

Look at the table. It gives information about these substances.

Substance	State at room temperature	Melting point (°C)	Boiling point (°C)	Solubility in water
A	liquid	0	100	soluble
B	liquid	-117	78	soluble
C	solid	1535	2750	insoluble

A and **B** mix together completely.

(a)* Suggest how the student can separate the mixture to get pure samples of substances **A**, **B** and **C**.

Explain in detail how each method works.

.....

.....

.....

.....

.....

.....

.....

.....

.....

.....

.....

.....

.....

.....

.....

.....

.....

.....

.....

.....

.....

.....

.....

.....

.....

.....

(b) The student has separated a **pure** sample of substance **B** from the mixture.

Suggest how the student can check that the sample of substance **B** is pure.

.....
.....
.....

[2]

SPECIMEN

21 Zinc nitrate can be made by reacting zinc oxide with nitric acid, HNO_3 .

(a) Write a **balanced symbol** equation for this reaction.

..... [2]

(b) Paul suggests this method for preparing zinc nitrate.

1. Measure 50cm^3 of dilute nitric acid into a beaker.
2. Add one spatulaful of zinc oxide.
3. Heat the mixture until crystals of zinc nitrate are made.

Paul's method will not make a pure dry sample of zinc nitrate.

What improvements should Paul make to the method to make sure that:

- the reaction is complete
- the zinc nitrate can be separated from the nitric acid and the zinc oxide?

Explain your answer.

.....
.....
.....
.....
.....
.....
..... [4]

(c) Describe why this reaction is a neutralisation reaction.

.....
.....
..... [2]

22 Magnesium burns in oxygen to make magnesium oxide.

The reaction involves both oxidation and reduction.

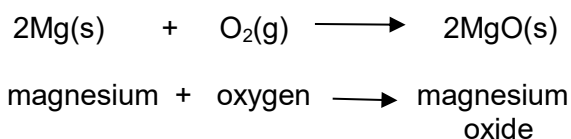

(a) **Complete** the sentence.

During this reaction, the oxidising agent is and the
reducing agent is

[1]

(b) Magnesium has an atomic number of 12.

Calculate the mean mass of an atom of magnesium. Quote your answer to **three** significant figures.

(Avogadro constant = 6.022×10^{23} atoms per mole)

Mean mass g

[2]

23 Meena electrolyses copper sulfate using copper electrodes.

Look at the diagram. It shows the apparatus she uses.

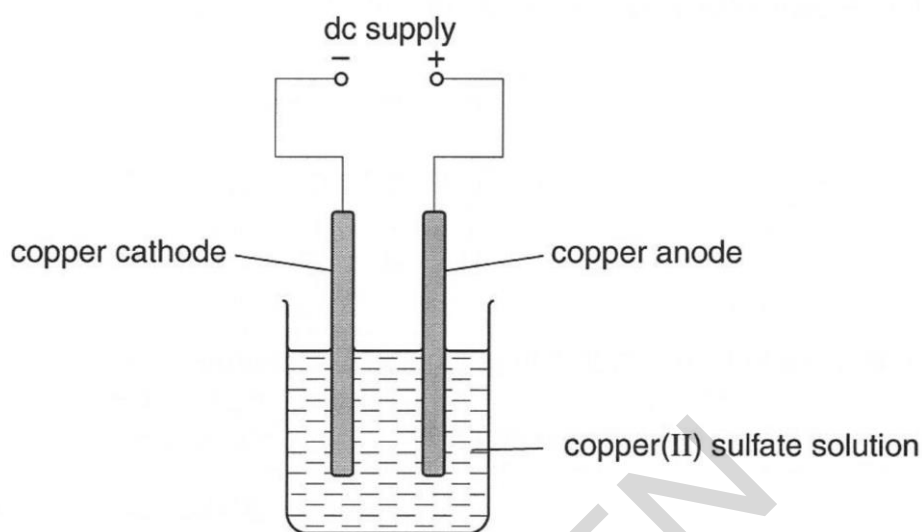

She investigates the change in mass at each electrode before and after the electrolysis.

Look at Meena's method.

1. Using a balance, measure the mass of the copper cathode and copper anode.
2. Set up the apparatus and run the electrolysis for 30 seconds.
3. Remove the copper cathode and the copper anode and immediately place them on the balance and measure their masses again.

(a) What improvements could you make to Meena's experiment?

Explain your answers.

.....

.....

.....

.....

.....

.....

.....

.....

.....

.....

[4]

(b) Meena finds that

- the cathode gains mass
- the anode loses mass.

Explain these observations in terms of the reactions at each electrode.

.....

.....

..... [2]

SPECIMEN

24 Look at the diagrams.

They show the structures of two compounds.

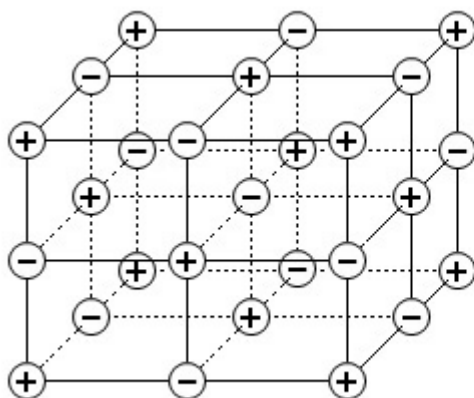

sodium chloride

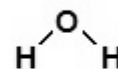

water

(a) Sodium chloride has a melting point of 801°C .

Use the structure of sodium chloride to explain why.

.....

.....

..... [2]

(b) Water has a low melting point and boiling point.

Explain why.

.....

.....

..... [2]

(c) Magnesium oxide has a similar structure to sodium chloride.

Draw 'dot and cross' diagrams to show the ionic bonding in magnesium oxide.

You should include the charges on the ions.

The electronic structure of magnesium is 2.8.2.

The electronic structure of oxygen is 2.6.

SPECIMEN

[3]

25 A student adds calcium to dilute hydrochloric acid. The mixture begins to fizz.

Write a balanced symbol equation for this reaction.

.....

[2]

END OF QUESTION PAPER

SPECIMEN