



Oxford Cambridge and RSA

AS Level Biology B (Advancing Biology)

H022/01 Foundations of biology

Thursday 24 May 2018 – Afternoon

Time allowed: 1 hour 30 minutes



You may use:

- a scientific or graphical calculator
- a ruler (cm/mm)



First name										
Last name										
Centre number						Candidate number				

INSTRUCTIONS

- Use black ink. You may use an HB pencil for graphs and diagrams.
- Complete the boxes above with your name, centre number and candidate number.
- Answer **all** the questions.
- Write your answer to each question in the space provided. If additional space is required, you should use the lined page(s) at the end of this booklet. The question number(s) must be clearly shown.
- Do **not** write in the barcodes.

INFORMATION

- The total mark for this paper is **70**.
- The marks for each question are shown in brackets [].
- This document consists of **28** pages.

2
SECTION A

You should spend a maximum of 25 minutes on this section.

Write your answer to each question in the box provided.

Answer **all** the questions.

1 Which of the options, **A** to **D**, is an **intracellular** biofluid?

- A blood plasma
- B cytoplasm
- C tissue fluid
- D serum

Your answer

[1]

2 A plant cell with a water potential of -500 KPa was placed in a solution which caused the cell membrane to completely pull away from the cell wall.

Which of the options, **A** to **D**, is the water potential of this solution?

- A -500 KPa
- B 0 KPa
- C -1000 KPa
- D -150 KPa

Your answer

[1]

- 3 A student was using an eyepiece graticule and a stage micrometer to calculate the length of a human cheek epithelial cell.

The following calibration and measurements were recorded:

- magnification of eyepiece lens = $\times 10$
- magnification of objective lens = $\times 10$
- 20 eyepiece divisions = 25 micrometer divisions
- each micrometer division = $10\ \mu\text{m}$
- length of epithelial cell observed = 6 eyepiece divisions.

Which of the rows, **A** to **D**, is correct?

	Total magnification	Length of one eyepiece division (μm)	Length of human cheek epithelial cell (μm)
A	20	12.5	75
B	100	50.0	300
C	100	12.5	75
D	20	50.0	300

Your answer

[1]

- 4 During the semi-conservative replication of DNA, which of the enzymes, **A** to **D**, is required to break hydrogen bonds between the nitrogen-containing bases?

- A** DNA polymerase
- B** DNA primase
- C** DNA ligase
- D** DNA helicase

Your answer

[1]

5 The number of chromosomes in a developing fetus can be checked by producing a karyogram.

Which of the options, **A** to **D**, about the production of a karyogram is **not** correct?

- A** fetal cells can be extracted from the placenta
- B** fetal cells are stimulated to divide by meiosis
- C** a chemical is added to stop cell division in metaphase
- D** the chromosomes are stained and photographed

Your answer

[1]

6 The photomicrographs show different types of leucocyte (white blood cell).

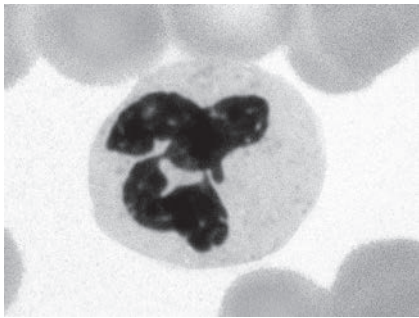

leucocyte A

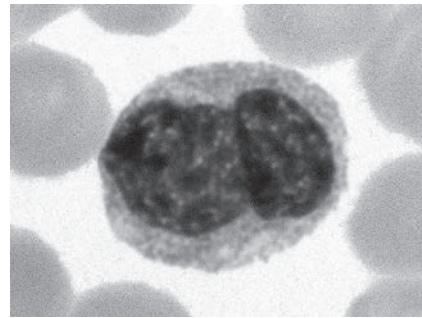

leucocyte B

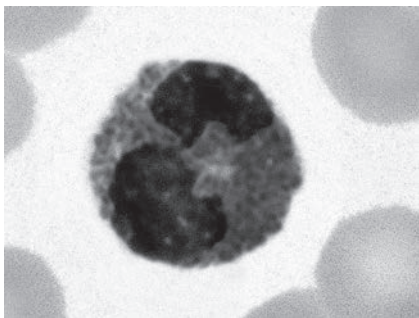

leucocyte C

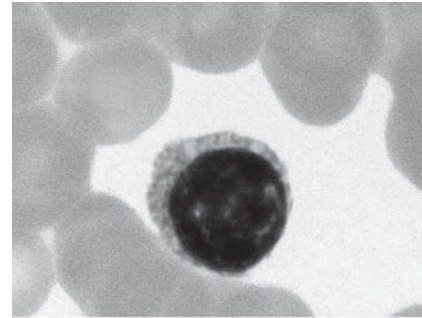

leucocyte D

Which of the leucocytes, **A** to **D**, can differentiate into a plasma cell during the specific immune response?

Your answer

[1]

7 The rate of transpiration can be affected by changing certain environmental factors.

Which of the options, **A** to **D**, are changes that would result in an **increased** rate of transpiration?

- A lower humidity and greater air movement
- B lower humidity and less air movement
- C higher humidity and greater air movement
- D higher humidity and less air movement

Your answer

[1]

8 A group of students investigated the effects of ethanol on the heart rate of the water flea, *Daphnia pulex*, and then analysed their results using a paired Student's *t*-test.

- Ten water fleas were used in the investigation.
- A value for *t* was calculated as 25.8.
- The critical value for a significance level of 5% is 2.23.

Which of the following statements, **A** to **D**, is correct?

- A The number of degrees of freedom is 10 and the null hypothesis can be rejected.
- B The number of degrees of freedom is 9 and the null hypothesis can be accepted.
- C The number of degrees of freedom is 9 and the null hypothesis can be rejected.
- D The number of degrees of freedom is 1 and the null hypothesis can be accepted.

Your answer

[1]

- 9 Plant life cycles show alternation of generations. The term alternation of generations is used to describe a process whereby mitosis and meiosis occur and the plant alternates between haploid and diploid forms during its life cycle.

Alternation of generations in the life cycle of a fern (*Polypodium* species) is shown in the diagram below.

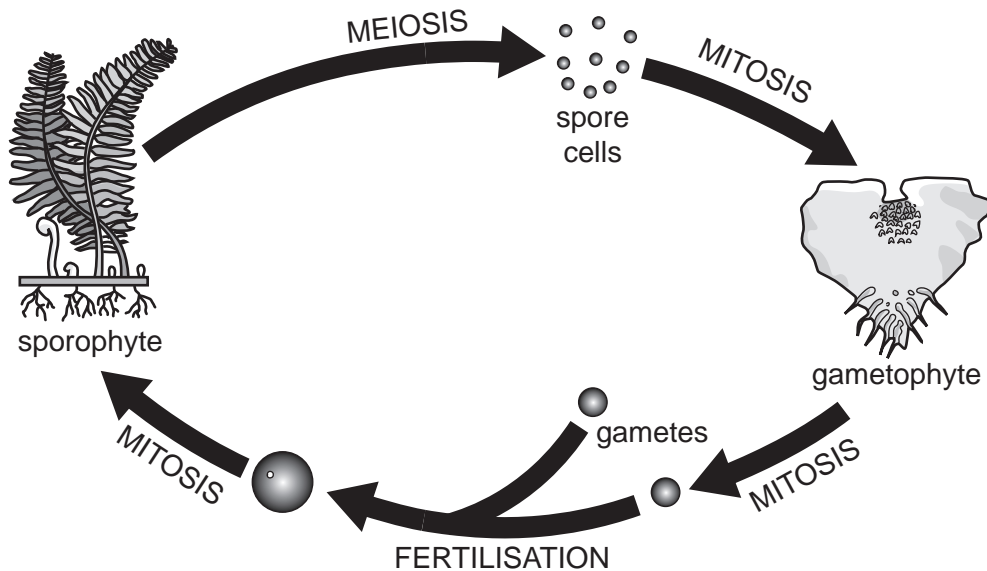

Which of the rows, **A** to **D**, is correct?

	Sporophyte	Gametophyte	Spore cell	Gamete
A	diploid	haploid	haploid	haploid
B	haploid	diploid	haploid	haploid
C	diploid	haploid	diploid	diploid
D	diploid	diploid	haploid	haploid

Your answer

[1]

- 10 Which of the structures, **A** to **D**, does **not** have smooth muscle tissue in its walls?

- A** trachea
- B** capillary
- C** bronchiole
- D** arteriole

Your answer

[1]

- 11 Three species, **X**, **Y** and **Z**, all evolved from a common ancestor. Species **X** and **Y** were the most closely related and species **Z** was extinct.

Which of the phylogenetic trees, **A** to **D**, represents the evolution of species **X**, **Y** and **Z**?

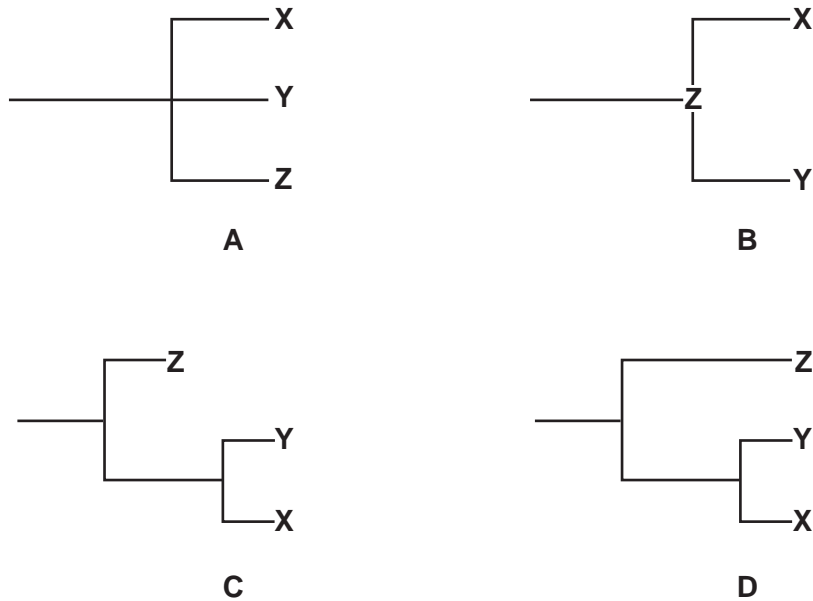

Your answer

[1]

- 12 Phloem loading is the process whereby plants move sucrose from a source into phloem sieve tubes.

During phloem loading, sucrose must be transported across the cell surface membranes of companion cells.

Which of the statements, **A** to **D**, about the transport of sucrose across the cell surface membrane of a companion cell is correct?

- A** Hydrogen ions are used to pump sucrose molecules through a carrier protein down a concentration gradient.
- B** Hydrogen ions are used to pump sucrose molecules through a carrier protein against a concentration gradient.
- C** Hydrogen ions and sucrose molecules are co-transported through a carrier protein as hydrogen ions move against their concentration gradient.
- D** Hydrogen ions and sucrose molecules are co-transported through a carrier protein as hydrogen ions move down their concentration gradient.

Your answer

[1]

13 The diagram shows a type of pathogen that can cause disease in humans.

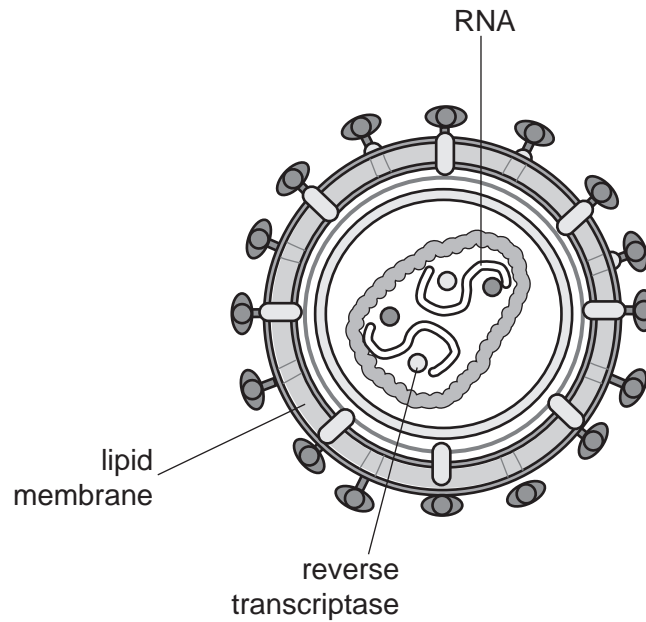

Which of the statements, **A** to **D**, correctly describes its mechanism of pathogenicity?

- A** damages host cells by using them to make its own proteins rather than host protein
- B** produces agglutinins that clump host cells together
- C** secretes enzymes that enable it to spread through host tissues
- D** produces antibodies against host cells

Your answer

[1]

14 The table shows the type of bond present in the different levels of structure for a protein molecule.

Which of the rows, **A** to **D**, is correct?

	Primary structure	Secondary structure	Tertiary structure
A	peptide	hydrogen	disulfide
B	hydrogen	peptide	ionic
C	peptide	disulfide	ionic
D	peptide	disulfide	hydrogen

Your answer

[1]

15 The following information describes a screening technique that can be used for detecting breast cancer:

- The patient must first be injected with a radioactive tracer.
- The scanner detects gamma radiation.
- The coloured images produced show differences between healthy and cancerous tissue.

Which of the screening techniques, **A** to **D**, is being described?

- A** Magnetic resonance imaging (MRI)
- B** Mammography
- C** Positron emission tomography (PET)
- D** Computerised tomography (CT)

Your answer

[1]

16 The table shows some of the properties of four types of blood vessel found in the human body.

Which of the blood vessels, **A** to **D**, is a vein?

Blood vessel	Lumen diameter (mm)	Wall thickness (μm)	Vascular blood pressure (mmHg)
A	0.02	1.0	50
B	0.008	0.5	20
C	5.0	500	5
D	4.0	1000	90

Your answer

[1]

17 Carbapenems are a class of broad-spectrum antibiotics.

In recent years, there has been an increase in the number of carbapenem-resistant strains of bacteria.

Which of the statements, **A** to **D**, would contribute to an increase in the number of carbapenem-resistant strains of bacteria?

- A** some bacteria develop immunity to carbapenems
- B** increased use of carbapenems in animal feed to prevent infection
- C** increased use of carbapenems causes mutations in the bacteria
- D** some bacteria have plasmids containing genes for carbapenems

Your answer

[1]

18 During her first antenatal appointment, a woman was advised that she needed to increase her current Dietary Reference Value (DRV) energy intake from 7800 KJ to 9200 KJ.

Which of the options, **A** to **D**, shows the correctly calculated percentage increase in DRV energy intake?

- A** 85%
- B** 118%
- C** 15%
- D** 18%

Your answer

[1]

19 The diagram shows the external structure of the mammalian heart.

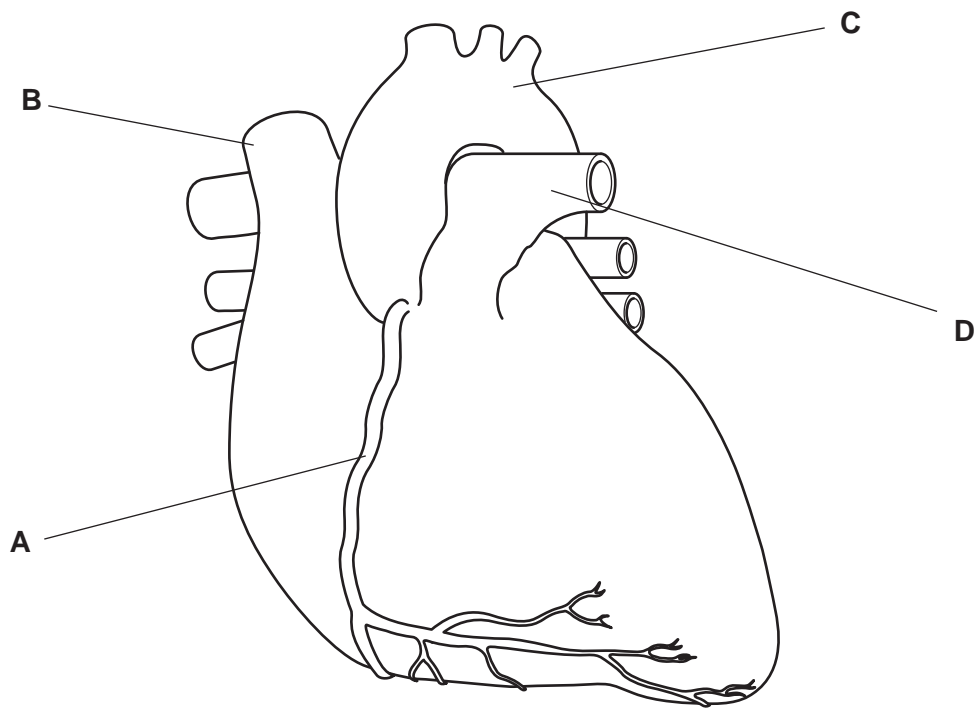

Which of the blood vessels, **A** to **D**, carry oxygenated blood to the heart muscle?

Your answer

[1]

20 Donated blood is processed into different products which can be used to treat patients with specific conditions.

Which of the patients, **A** to **D**, would be treated by using a transfusion of **platelets**?

- A** receiving regular blood transfusions
- B** has bone marrow failure
- C** has low concentration of clotting factors
- D** undergoing cardiac surgery

Your answer

[1]

SECTION B

Answer **all** the questions.

21 Certain geographical regions of the Earth have high species diversity including large numbers of species that are unique to these regions. Such species are called endemic species.

(a) (i) What is meant by the term species diversity?

.....
.....
..... [2]

(ii) Some geographical regions are threatened with habitat loss and have been prioritised for conservation. Such regions are known as biodiversity hotspots.

To be identified as a biodiversity hotspot a region must:

- have at least 0.5% of the Earth’s 300 000 plant species as endemic species;
- have lost at least 70% of its original habitat.

Table 21 shows some data about two geographical regions, Madagascar and New Zealand.

Geographical region	Original habitat (km ²)	Remaining habitat (km ²)	Number of endemic plant species
Madagascar	594 150	59 038	9704
New Zealand	270 500	59 400	1865

Table 21

Analyse the data in Table 21 **and** compare these geographical regions as potential biodiversity hotspots.

.....
.....
.....
.....
.....
.....
.....
.....
..... [4]

- (b) The rosy periwinkle, *Catharanthus roseus*, is one of the plant species found in Madagascar where it has evolved adaptations to survive in the hot and humid climate.

Describe the adaptations that plants such as *C. roseus* could have evolved to survive in a hot and humid climate?

.....
.....
.....
..... [2]

- (c) Researchers have discovered that the leaves of *C. roseus* contain chemicals that can disrupt mitosis in actively dividing cells.

- (i) Suggest a potential medicinal use for these chemicals.
..... [1]

- (ii) One of these chemicals acts by binding to spindle fibres to prevent the separation of sister chromatids.

Which **stage** of mitosis is prevented by this chemical?
..... [1]

- (d) Genetic diversity was investigated in coloured variants of *C. roseus*.

Genetic data from an analysis of 56 genes showed that 10 of these genes were monomorphic.

Calculate the proportion of polymorphic genes in this population of *C. roseus*.

Give your answer to **two** significant figures.

Answer = [2]

- 22 An ectopic pregnancy occurs when a fertilised egg cell implants outside the uterus, often in a fallopian tube. Methotrexate is an enzyme inhibitor that has been used in the medical treatment of ectopic pregnancies.

Fig. 22 shows the enzyme reaction inhibited by methotrexate.

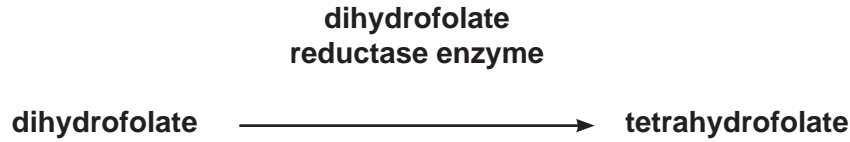

Fig. 22

- (a) The relative concentrations of dihydrofolate and methotrexate determine the rate of the reaction shown in Fig. 22, but the maximum rate of reaction can still be achieved even in the presence of methotrexate.

- (i) Explain how the maximum rate of the reaction can still be achieved despite the presence of methotrexate.

.....
.....
.....
.....
.....
.....
.....
.....
..... [3]

- (ii) Tetrahydrofolate is essential in subsequent reactions that synthesise purine nucleotides.
Name **two** purine nucleotides.

1

2 [1]

- (iii) Explain why methotrexate will eventually cause the death of the fertilised egg cell in an ectopic pregnancy.

.....
.....
.....
..... [2]

(b) Aspirin is another example of an enzyme inhibitor that can be used for medical purposes.

Aspirin acts as an anti-prostaglandin so is commonly used to treat inflammation and relieve pain.

Give **one** other effect of aspirin in the human body.

.....
..... [1]

Turn over for the next question

23 Water is an important biological molecule.

- (a) The table below shows some of the properties of water and their importance to living organisms.

Complete the table using the most appropriate term(s) or sentence(s).

Property of water	Importance to living organisms
<p>.....</p> <p>.....</p>	<p>allows chemical reactions to take place inside cells</p>
<p>has a high latent heat of vaporisation</p>	<p>.....</p> <p>.....</p>
<p>.....</p> <p>.....</p>	<p>allows a continuous column of water to move through xylem vessels without breaking</p>
<p>has a high specific heat capacity</p>	<p>.....</p> <p>.....</p>

[4]

- (b) Water also plays an important role in the reactions involved in the formation and breakdown of macromolecules in the human body.

Fig. 23.1 shows the formation and breakdown of one type of macromolecule.

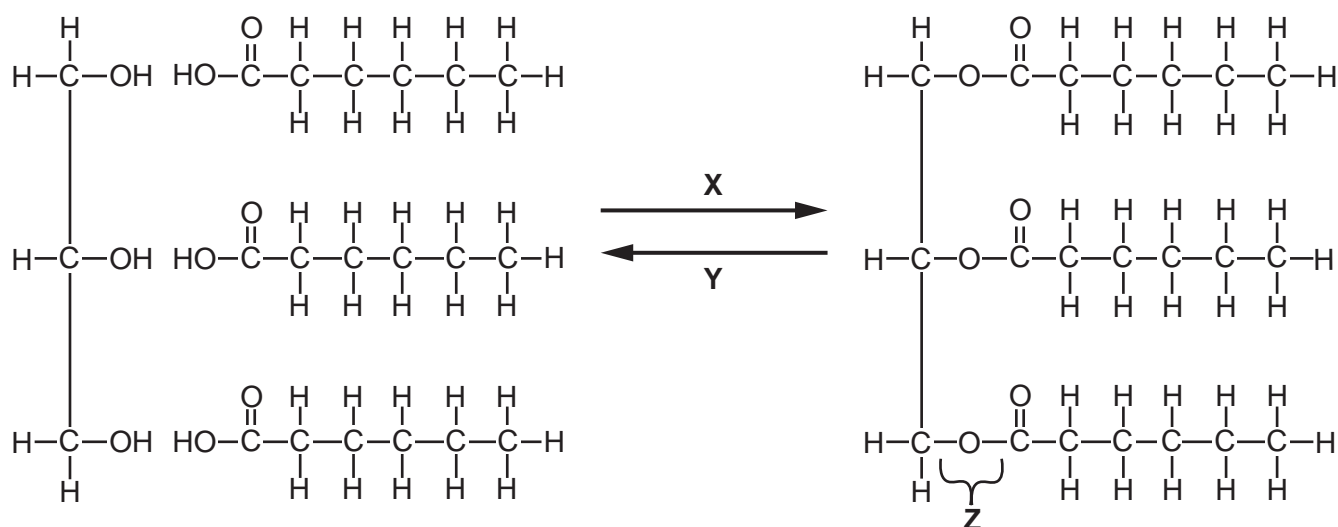

Fig. 23.1

- (i) Name the types of reaction taking place at X and Y.

Reaction X

Reaction Y

[1]

- (ii) Name **both** products of reaction X.

..... [1]

- (iii) Name the bond labelled Z.

..... [1]

- (c) It is essential to the functioning of the human body to maintain the correct balance of water and dissolved nutrients.

Cyclospora cayetanensis and *Campylobacter jejuni* are microorganisms that cause diarrhoea in humans leading to excessive water loss.

Fig. 23.2 shows some of the data recorded for infections caused by these microorganisms in a human population during the year 2014.

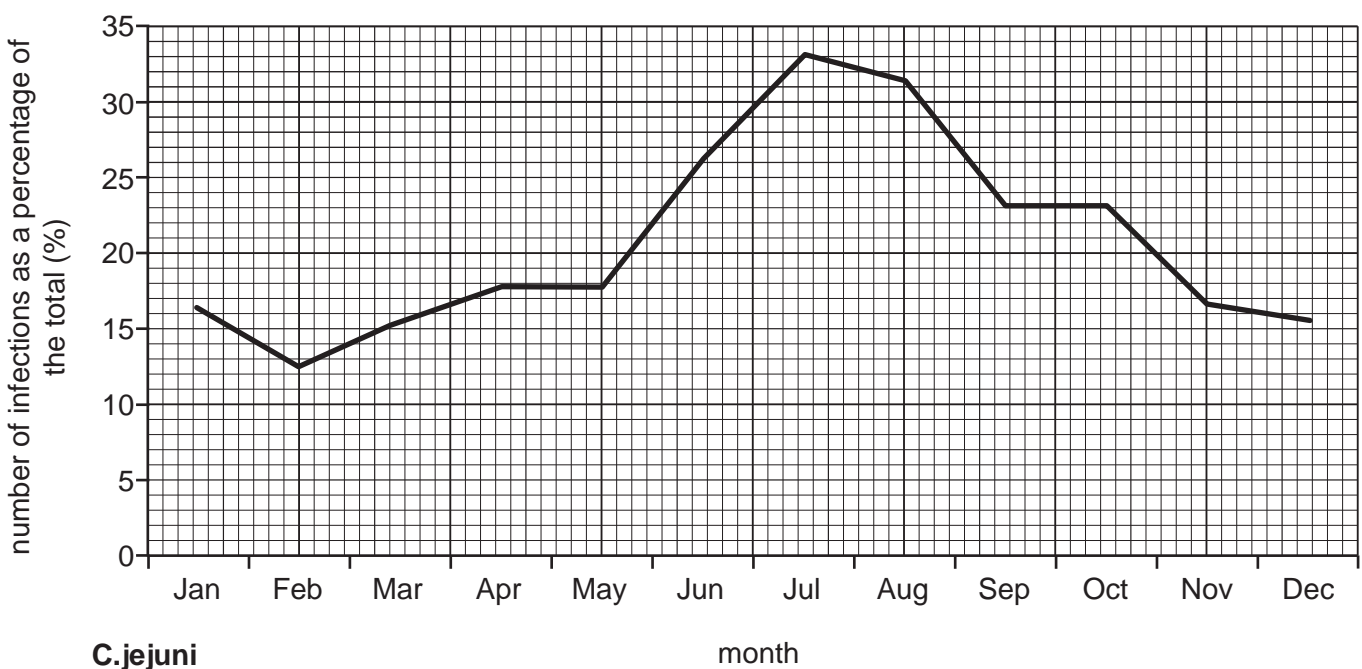
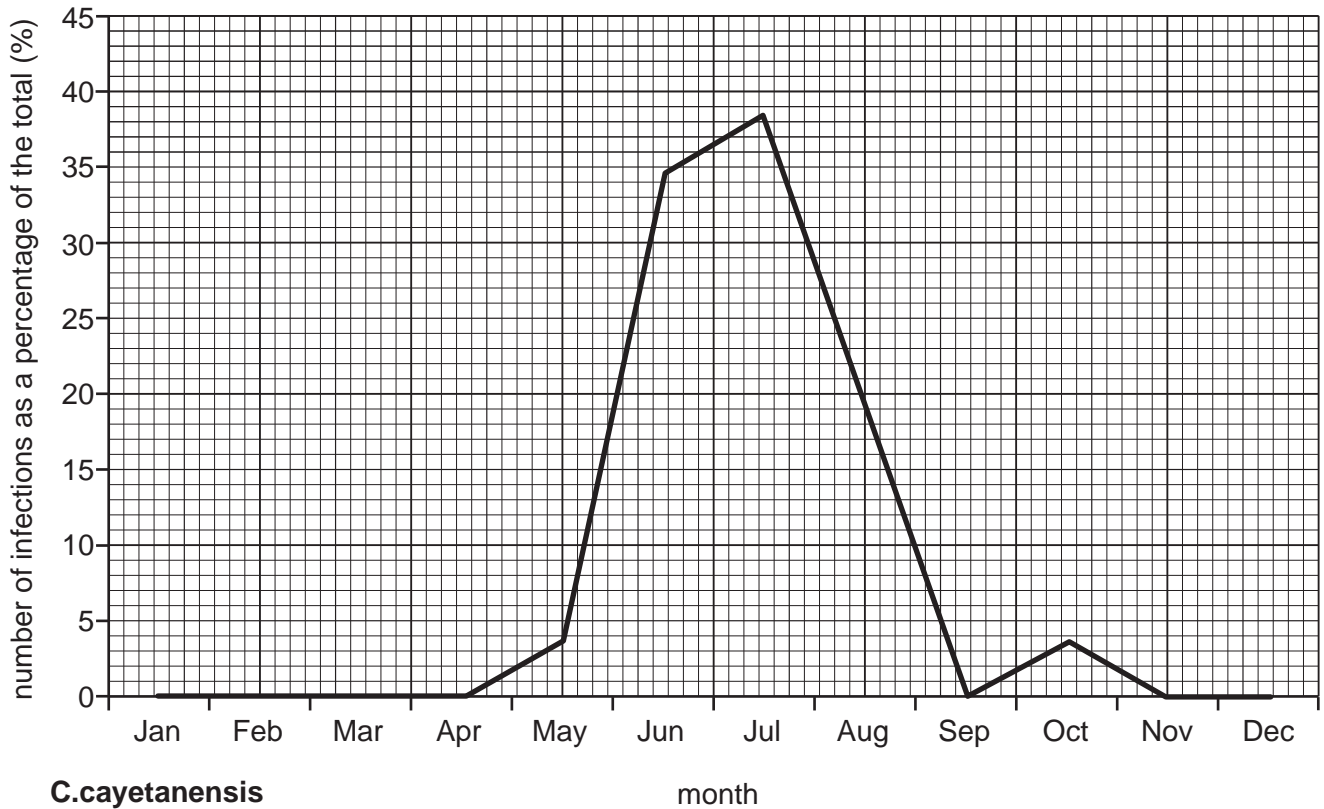

Fig. 23.2

- (i) Comment on the trends shown by the data in Fig. 23.2 for the infection caused by *C.jejuni*.

.....

.....

.....

..... [2]

- (ii) The data for the infection caused by *C.cayetanensis* suggests that an epidemic occurred between the months of May and August.

Comment on the validity of this suggestion.

.....

.....

.....

..... [2]

(d) Fig. 23.3 is a transmission electron micrograph (TEM) of a *C.jejuni* bacterium.

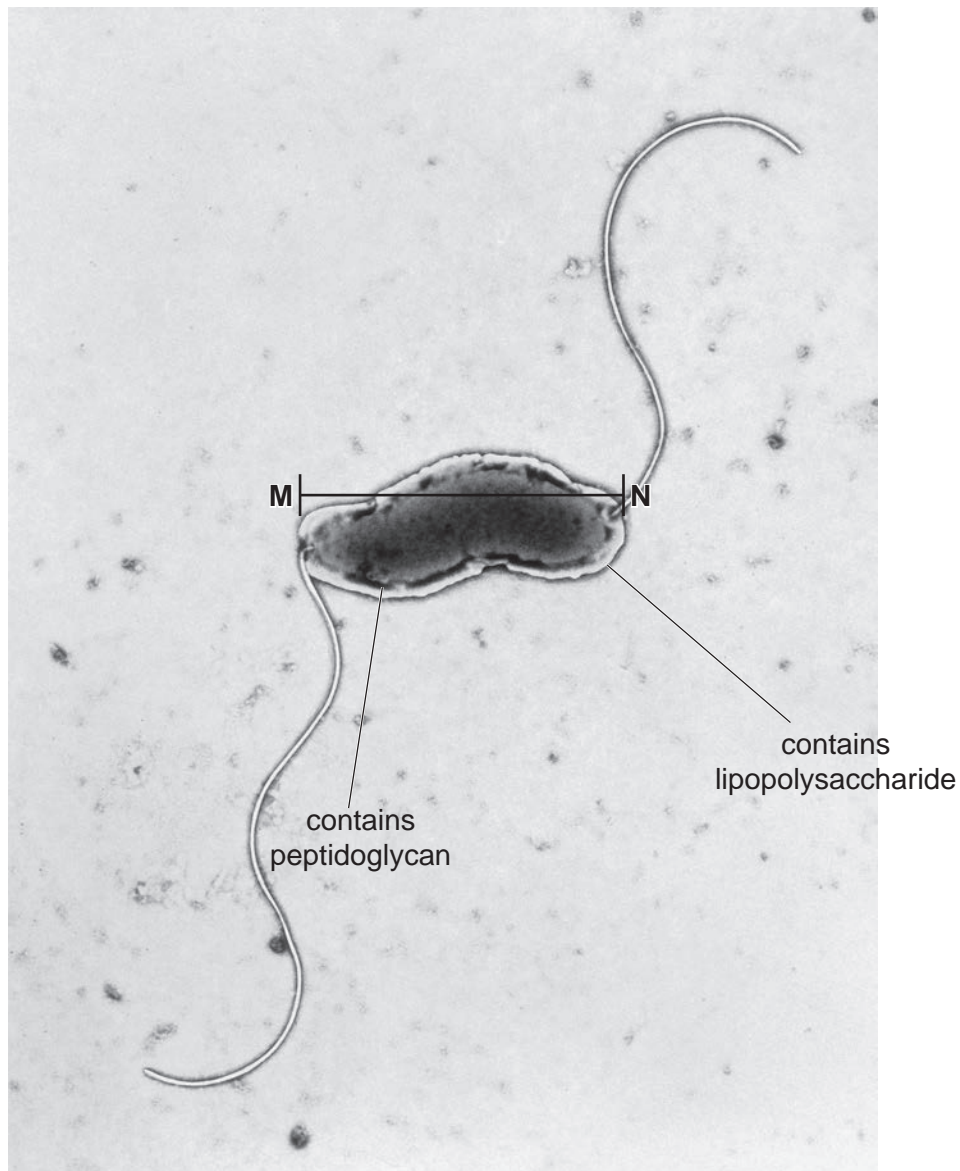

Fig. 23.3

- (i) The actual length of the bacterium shown in Fig. 23.3 between points **M** and **N** is $4\ \mu\text{m}$. Calculate the magnification of the micrograph. Give your answer to **three** significant figures.

Answer = x [2]

24 Different types of monitors are available for medical practitioners to measure the blood pressure of their patients.

These may include:

- digital upper arm monitor
- digital wrist monitor
- manual upper arm monitor

These blood pressure monitors all have inflatable cuffs.

(a) (i) Give **one** advantage of using a digital monitor for measuring blood pressure.

.....
..... [1]

(ii) Sources of error when taking blood pressure measurements using these monitors include improper technique and observer bias.

Suggest **two other** sources of error when using these monitors for measuring blood pressure.

.....
.....
.....
..... [2]

(iii) Fig. 24 shows the variation in systolic pressure in different arteries.

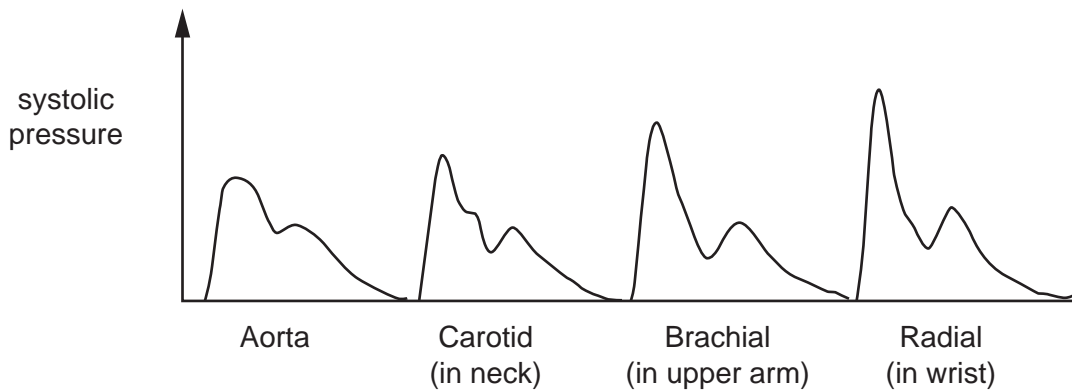

Fig. 24

Using the information in Fig. 24, comment on the suitability of using a digital wrist monitor for measuring blood pressure.

.....
.....
.....
.....
..... [2]

(b) Hemorrhagic shock is a clinical syndrome resulting from decreased blood volume caused by blood loss. Hypotension may occur in hemorrhagic shock patients where blood loss is greater than 15% of the total blood volume.

(i) Explain how the production of tissue fluid is affected in patients suffering from hemorrhagic shock syndrome.

.....
.....
.....
..... [2]

(ii) In cases of severe blood loss, the body actively reabsorbs fluid from the tissues to restore blood volume.

Suggest how the composition of this restored blood would differ from that of the blood that has been lost.

.....
.....
.....
..... [2]

25 Allergens, such as pollen, are non-pathogenic but can trigger an immune response. This is known as an allergic reaction.

- (a)** Complete the passage below about an allergic reaction using the most appropriate words or phrases.

Exposure to an allergen triggers the production of IgE antibodies which bind to cells. The allergen molecules then bind to the variable region of the IgE antibodies causing a chemical called to be released from the cells by This chemical increases the permeability of resulting in the formation of excess tissue fluid that leads to swelling and irritation associated with an inflammatory response. **[4]**

- (b)** The symptoms of asthma can be triggered by allergens.

The table below shows information about two types of drug that are used in inhalers to treat the symptoms of asthma.

Complete the table by inserting a tick (✓) or a cross (✗) as appropriate for each drug.

Drug	Reduce inflammation of the bronchi	Widen the lumen of the bronchi	Can be used during an acute asthma attack
Corticosteroids			
Beta-agonists			

[2]

END OF QUESTION PAPER

ADDITIONAL ANSWER SPACE

If additional space is required, you should use the following lined page(s). The question number(s) must be clearly shown in the margin(s).

A large area of lined paper for writing. It features a vertical solid line on the left side, creating a margin. The rest of the page is filled with horizontal dotted lines, providing space for writing answers.

A blank sheet of lined paper. It features a vertical solid line on the left side, creating a margin. The rest of the page is filled with horizontal dotted lines, providing a guide for writing. There are 25 rows of dotted lines in total.

A large area of the page is reserved for writing, featuring a vertical solid line on the left side and horizontal dotted lines extending across the page.



Copyright Information

OCR is committed to seeking permission to reproduce all third-party content that it uses in its assessment materials. OCR has attempted to identify and contact all copyright holders whose work is used in this paper. To avoid the issue of disclosure of answer-related information to candidates, all copyright acknowledgements are reproduced in the OCR Copyright Acknowledgements Booklet. This is produced for each series of examinations and is freely available to download from our public website (www.ocr.org.uk) after the live examination series.

If OCR has unwittingly failed to correctly acknowledge or clear any third-party content in this assessment material, OCR will be happy to correct its mistake at the earliest possible opportunity.

For queries or further information please contact the Copyright Team, First Floor, 9 Hills Road, Cambridge CB2 1GE.

OCR is part of the Cambridge Assessment Group; Cambridge Assessment is the brand name of University of Cambridge Local Examinations Syndicate (UCLES), which is itself a department of the University of Cambridge.