



**General Certificate of Education (A-level)  
January 2013**

**Chemistry**

**CHEM4**

**(Specification 2420)**

**Unit 4: Kinetics, Equilibria and Organic  
Chemistry**

**Final**

***Mark Scheme***

---

Mark schemes are prepared by the Principal Examiner and considered, together with the relevant questions, by a panel of subject teachers. This mark scheme includes any amendments made at the standardisation events which all examiners participate in and is the scheme which was used by them in this examination. The standardisation process ensures that the mark scheme covers the students' responses to questions and that every examiner understands and applies it in the same correct way. As preparation for standardisation each examiner analyses a number of students' scripts: alternative answers not already covered by the mark scheme are discussed and legislated for. If, after the standardisation process, examiners encounter unusual answers which have not been raised they are required to refer these to the Principal Examiner.

It must be stressed that a mark scheme is a working document, in many cases further developed and expanded on the basis of students' reactions to a particular paper. Assumptions about future mark schemes on the basis of one year's document should be avoided; whilst the guiding principles of assessment remain constant, details will change, depending on the content of a particular examination paper.

Further copies of this Mark Scheme are available from: [aqa.org.uk](http://aqa.org.uk)

Copyright © 2013 AQA and its licensors. All rights reserved.

**Copyright**

AQA retains the copyright on all its publications. However, registered centres for AQA are permitted to copy material from this booklet for their own internal use, with the following important exception: AQA cannot give permission to centres to photocopy any material that is acknowledged to a third party even for internal use within the centre.

Set and published by the Assessment and Qualifications Alliance.

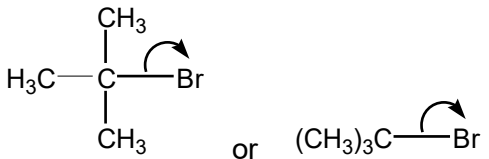
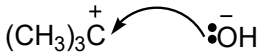
Question	Marking Guidance	Mark	Comments
1(a)(i)	$k = \frac{8.4 \times 10^{-5}}{(4.2 \times 10^{-2})^2 \times 2.6 \times 10^{-2}} \quad \text{OR} \quad \frac{8.4 \times 10^{-5}}{(1.76 \times 10^{-3}) \times 2.6 \times 10^{-2}}$ $= 1.8(3)$ $\text{mol}^{-2} \text{dm}^6 \text{s}^{-1}$	1  1  1	Mark is for insertion of numbers into a correctly rearranged rate equ , k = etc. If upside down, score only units mark from their k AE (-1) for copying numbers wrongly or swapping two numbers Any order If k calculation wrong, allow units consequential to their k = expression
1(a)(ii)	$5.67 \times 10^{-4} \text{ (mol dm}^{-3}\text{s}^{-1}) \quad \text{OR} \quad \text{their } k \times 3.1 \times 10^{-4}$	1	Allow $5.57 \times 10^{-4}$ to $5.7 \times 10^{-4}$
1(b)(i)	2 or second or $[D]^2$	1	
1(b)(ii)	0 or zero or $[E]^0$	1	
1(c)(i)	Step 1 or equation as shown	1	Penalise Step 2 but mark on
1(c)(ii)	 <p>Ignore correct partial charges, penalise full / incorrect partial charges</p>	1	If Step 2 given above, can score the mark here for  allow :OH <sup>-</sup> (must show lp) If S <sub>N</sub> 2 mechanism shown then no mark (penalise involvement of :OH <sup>-</sup> in step 1) Ignore anything after correct step 1

Question	Marking Guidance	Mark	Comments
2(a)(i)	$[H^+][OH^-]$ <b>OR</b> $[H_3O^+][OH^-]$ Ignore (aq)	1	Must have [ ] not ( )
2(a)(ii)	$\sqrt{3.46 \times 10^{-14}}$ (= $1.86 \times 10^{-7}$ ) pH = 6.73	1 1	If no square root, CE=0 <b>Must be 2dp</b>
2(a)(iii)	$[H^+] = 10^{-11.36}$ (= $4.365 \times 10^{-12}$ OR $4.37 \times 10^{-12}$ ) $K_w = [4.365 \times 10^{-12}$ <b>OR</b> $4.37 \times 10^{-12} \times 0.047] = 2.05 \times 10^{-13}$ Allow $2.05 \times 10^{-13}$ - $2.1 \times 10^{-13}$	1 1	Mark for working Mark for answer Ignore units
2(b)(i)	$HCOOH \rightleftharpoons HCOO^- + H^+$ <b>OR</b> $HCOOH + H_2O \rightleftharpoons HCOO^- + H_3O^+$	1	Must have $\rightleftharpoons$ but ignore brackets. Allow $HCO_2^-$ or $CHOO^-$ ie minus must be on oxygen, so penalise $COOH^-$
2(b)(ii)	$K_a = \frac{[H^+][HCOO^-]}{[HCOOH]}$ <b>OR</b> $\frac{[H_3O^+][HCOO^-]}{[HCOOH]}$	1	Must have all brackets but allow ( ) Must be HCOOH etc. Allow ecf in formulae from 2(b)(i)
2(b)(iii)	M1 $K_a = \frac{[H^+]^2}{[HCOOH]}$ ( $[H^+]^2 = 1.78 \times 10^{-4} \times 0.056 = 9.97 \times 10^{-6}$ ) M2 $[H^+] = 3.16 \times 10^{-3}$ M3 pH = 2.50 allow more than 2 dp but not fewer	1 1 1	Allow HA or HX etc. Allow $[H^+] = \sqrt{(K_a \times [HA])}$ for M1 Mark for answer <b>Allow correct pH from their wrong <math>[H^+]</math> here only</b> If square root shown but not taken, pH = 5.00 can score max 2 for M1 and M3

2(b)(iv)	M1	Decrease <b>Mark M1 independently</b>	1	<b>Only award M3 following correct M2</b>
	M2	Equm <u>shifts/moves</u> to RHS <b>OR</b> more H <sup>+</sup> <b>OR</b> K <sub>a</sub> increases <b>OR</b> more dissociation	1	
	M3	To reduce temperature or oppose increase/change in temperature	1	
2(c)(i)	M1	$[H^+] = \frac{K_a \times [HX]}{[X^-]}$ <b>OR</b> $pH = pK_a - \log \frac{[HX]}{[X^-]}$	1	If [HX]/[X <sup>-</sup> ] upside down, no marks
	M2	$\frac{1.78 \times 10^{-4} \times 2.35 \times 10^{-2}}{1.84 \times 10^{-2}}$ <b>OR</b> $pH = 3.75 - \log \frac{2.35 \times 10^{-2}}{1.84 \times 10^{-2}}$ (= 2.27 × 10 <sup>-4</sup> )	1	<b>pH calc NOT allowed from their wrong [H<sup>+</sup>] here</b>
	M3	pH = 3.64 allow more than 2 dp but not fewer	1	
2(c)(ii)	M1	Mol H <sup>+</sup> added = 5.00 × 10 <sup>-4</sup>	1	Mark on from AE in moles of HCl (eg 5 × 10 <sup>-3</sup> gives pH = 3.42 scores 3)
	M2	Mol HCOOH = 2.40 × 10 <sup>-2</sup> <b>and</b> Mol HCOO <sup>-</sup> = 1.79 × 10 <sup>-2</sup>	1	If either wrong no further marks except AE (-1) <b>OR</b> if ECF in mol acid and/or mol salt from (c)(i), can score all 4
	M3	$[H^+] (= \frac{K_a \times [HX]}{[X^-]}) = \frac{1.78 \times 10^{-4} \times 2.40 \times 10^{-2}}{1.79 \times 10^{-2}}$ (= 2.39 × 10 <sup>-4</sup> ) <b>OR</b> $pH = 3.75 - \log \frac{2.40 \times 10^{-2}}{1.79 \times 10^{-2}}$	1	If [HX]/[X <sup>-</sup> ] upside down here after correct expression in (c)(i), no further marks If [HX]/[X <sup>-</sup> ] upside down here and is repeat error from (c)(i), max 3 (pH = 3.88 after 3.86 in 2(c)(i))
	M4	pH = 3.62 allow more than 2 dp but not fewer	1	<b>pH calc NOT allowed from their wrong [H<sup>+</sup>] here</b>

Question	Marking Guidance	Mark	Comments	
3(a)(i)	$\underline{3}\text{CH}_3\text{OH}$	1	Not molecular formula	
	$\text{HOCH}_2\text{CH}(\text{OH})\text{CH}_2\text{OH}$	1		
3(a)(ii)	$\text{C}_{17}\text{H}_{35}\text{COOCH}_3 + 27\frac{1}{2}$ or $55/2 \text{ O}_2$	1	Or doubled Consequential on correct right-hand side	
	$\rightarrow 19\text{CO}_2 + 19\text{H}_2\text{O}$	1		
3(b)(i)	A	0.7	1	
	Ethanol	6.4	1	
	Water	3.6	1	
3(b)(ii)	No effect	1	If wrong, CE= 0	
	Equal moles on each side of equation <b>OR</b> V cancels	1	Ignore moles of gas	
3(b)(iii)	M1 $K_c = \frac{[\text{DEM}][\text{H}_2\text{O}]^2}{[\text{A}][\text{C}_2\text{H}_5\text{OH}]^2}$	1	Must have all brackets but allow ( )	
3(b)(iv)	M2	$\frac{2.1 \times (3.4)^2}{0.85 \times (7.2)^2}$	1	If $K_c$ wrong can only score M4 for units consequential to their $K_c$ working in (b)(iv)
	M3	0.55 (min 2dp)	1	
	M4	No units	1	

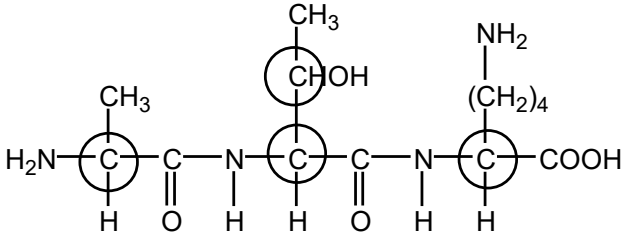
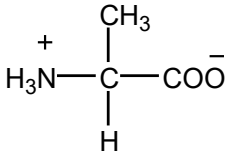
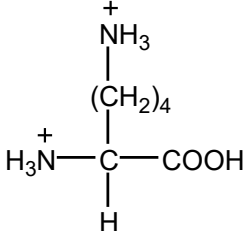
Question	Marking Guidance	Mark	Comments
4(a)(i)		1	These four only
4(a)(ii)		1	Allow $\text{-NH}_3^+$ and $^+\text{NH}_3\text{-}$
4(a)(iii)	<p><u>2-amino-3-hydroxybutanoic acid</u></p> <p>Do not penalise commas or missing hyphens</p>	1	Ignore 1 in butan-1-oic acid Penalise other numbers
4(a)(iv)		1	Allow $\text{-NH}_3^+$ and $^+\text{NH}_3\text{-}$

4(b)(i)	Condensation	1	Allow polyester
4(b)(ii)	<u>propane-1,3-diol</u>	1	Must have e Allow 1,3-propan <u>e</u> diol
4(c)(i)	Addition	1	Not additional
4(c)(ii)	$\begin{array}{c} \text{H} & \text{F} \\   &   \\ \text{C} & = & \text{C} \\   &   \\ \text{H} & \text{F} \end{array}$ and $\begin{array}{c} \text{F} & \text{CF}_3 \\   &   \\ \text{C} & = & \text{C} \\   &   \\ \text{F} & \text{F} \end{array}$ OR $\begin{array}{c} \text{F} & \text{F} \\   &   \\ \text{C} & = & \text{C} \\   &   \\ \text{F} & \text{F} \end{array}$ and $\begin{array}{c} \text{F}_3\text{C} & \text{H} \\   &   \\ \text{C} & = & \text{C} \\   &   \\ \text{F} & \text{H} \end{array}$	1 for each structure within each pair	Allow monomers drawn either way round Allow bond to F in CF <sub>3</sub>
4(d)	c	1	If wrong, CE = 0
	C-C or C-F bonds too strong	1	

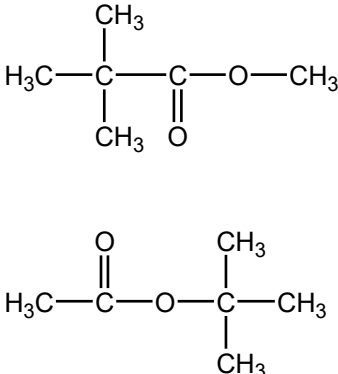
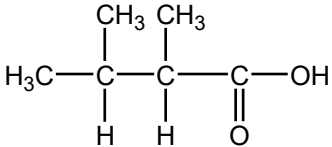
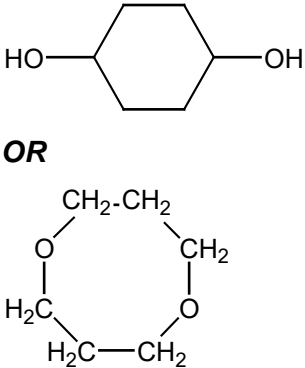
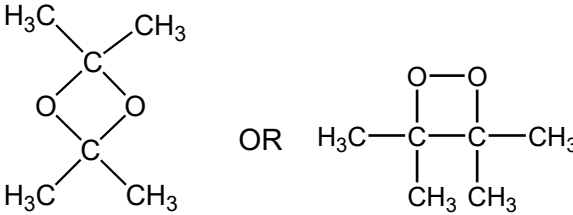

Question	Marking Guidance	Mark	Comments
5(a)(i)	Single/one (intense) peak/signal <b>OR</b> all H or all C in same environment <b>OR</b> 12 equiv H or 4 equiv C <b>OR</b> Upfield / to the right of (all) other peaks <b>OR</b> well away from others <b>OR</b> doesn't interfere with other peaks <b>OR</b> Low bp <b>OR</b> volatile <b>OR</b> can easily be removed	2	<b>Do not allow non-toxic or inert (both given in Q)</b> Any 2 from three Ignore peak at zero Ignore cheap Ignore non-polar Ignore mention of solubility
5(a)(ii)	$\begin{array}{c} \text{CH}_3 \\   \\ \text{H}_3\text{C}-\text{Si}-\text{CH}_3 \\   \\ \text{CH}_3 \end{array}$	1	Allow $\text{Si}(\text{CH}_3)_4$
5(b)(i)	$\begin{array}{c} \text{---C---CH}_3 \\    \\ \text{O} \end{array}$ or with sticks or $\begin{array}{c}   \\ \text{R---C---C---} \\    \quad   \\ \text{O} \quad \text{H} \end{array}$	1	Ignore any group joined on other side of CO Ignore missing trailing bond Ignore charges
5(b)(ii)	$\text{CH}_3\text{---CH}_2\text{---O---}$ or with sticks	1	Ignore any group joined on other side of $\text{---O---}$ Ignore missing trailing bond Ignore charges as if MS fragment
5(b)(iii)	$\text{---O---CH}_2\text{---CH}_2\text{---C---}$ or with sticks $\begin{array}{c} \text{---O---CH}_2\text{---CH}_2\text{---C---} \\    \\ \text{O} \end{array}$	1	Ignore missing trailing bond Ignore charges as if MS fragment
5(b)(iv)	$\text{CH}_3\text{---CH}_2\text{---O---CH}_2\text{---CH}_2\text{---C---CH}_3$ $\begin{array}{c} \text{CH}_3\text{---CH}_2\text{---O---CH}_2\text{---CH}_2\text{---C---CH}_3 \\    \\ \text{O} \end{array}$	1	

5(c)(i)	<p style="text-align: center;">Check structure has 6 carbons</p> 	<p style="text-align: center;">1</p>	<p>Allow <math>(\text{CH}_3)_3\text{CCOOCH}_3</math> or <math>(\text{CH}_3)_3\text{CCO}_2\text{CH}_3</math></p>
5(c)(ii)	<p style="text-align: center;">Check structure has 6 carbons</p> 	<p style="text-align: center;">1</p>	<p>Allow <math>(\text{CH}_3)_2\text{CHCH}(\text{CH}_3)\text{COOH}</math> or <math>(\text{CH}_3)_2\text{CHCH}(\text{CH}_3)\text{CO}_2\text{H}</math></p> <p>Penalise <math>\text{C}_3\text{H}_7</math></p>
5(c)(iii)	<p style="text-align: center;">Check structure has 6 carbons</p>  <p><b>OR</b></p>	<p style="text-align: center;">1</p>	<p>Allow</p> 

Question	Marking Guidance				Mark	Comments		
6	In each section <ul style="list-style-type: none"> <li>If wrong or no reagent given, no marks for any observations;</li> <li>Penalise incomplete reagent or incorrect formula – but mark observations</li> <li>Mark each observation independently</li> <li>Allow <i>no reaction</i> for no change / no observable reaction in all three parts, but not <i>none</i> or <i>nothing</i></li> <li>Q says <b>one test</b>. If two tests are given, score zero</li> </ul>							
6(a)		$K_2Cr_2O_7 / H^+$	$KMnO_4 / H^+$	Lucas test ( $ZnCl_2 / HCl$ )	1	Allow acidified potassium manganate and acidified potassium dichromate without oxidation numbers		
	<b>R</b> Primary alcohol	(Orange) goes green Penalise wrong starting colour	(purple) goes colourless / decolourises allow goes brown	No cloudiness	1			
	<b>S</b> Tertiary alcohol	no change / no observable reaction	no change / no observable reaction	Rapid cloudiness	1			
6(b)		$Na_2CO_3 / NaHCO_3$ named carbonate	metal eg Mg	named indicator	1	$PCl_5$ $PCl_3$ $SOCl_2$	Named alcohol + $HCl / H_2SO_4$	
	<b>T</b> ester	no change / no observable reaction	no change / no observable reaction	no effect	1	no change / no observable reaction	no change / no observable reaction	
	<b>U</b> Acid	Effervescence or ( $CO_2$ ) gas formed	Effervescence or ( $H_2$ ) gas formed	acid colour	1	Fumes / ( $HCl$ ) gas formed	Sweet smell	

Question	Marking Guidance				Mark	Comments		
	In each section <ul style="list-style-type: none"> <li>• If wrong or no reagent given, no marks for any observations;</li> <li>• Penalise incomplete reagent or incorrect formula – but mark observations</li> <li>• Mark each observation independently</li> <li>• Allow <i>no reaction</i> for no change / no observable reaction in all three parts, but not <i>none</i> or <i>nothing</i></li> <li>• Q says <b>one test</b>. If two tests are given, score zero</li> </ul>							
6(c)		Fehling's / Benedict's	Tollens' / [Ag(NH <sub>3</sub> ) <sub>2</sub> ] <sup>+</sup>	K <sub>2</sub> Cr <sub>2</sub> O <sub>7</sub> / H <sup>+</sup>	1	I <sub>2</sub> / NaOH		
	<b>V</b> Ketone	no change / no observable reaction	no change / no observable reaction	no change / no observable reaction	1	Yellow ppt		
	<b>W</b> aldehyde	Red <u>ppt</u>	Silver mirror	(Orange) goes green Penalise wrong starting colour	1	no change / no observable reaction		

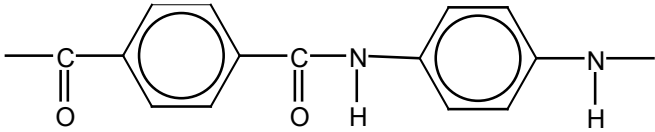
Question	Marking Guidance	Mark	Comments
7(a)	<p>Sn / HCl <b>OR</b> Fe / HCl not conc H<sub>2</sub>SO<sub>4</sub> nor any HNO<sub>3</sub>                      Ignore subsequent use of NaOH</p> <p><b>Equation must use molecular formulae</b>                      C<sub>6</sub>H<sub>4</sub>N<sub>2</sub>O<sub>4</sub> + 12 [H]                      → C<sub>6</sub>H<sub>8</sub>N<sub>2</sub> + 4H<sub>2</sub>O</p> 	<p>1</p> <p>1</p> <p>1</p> <p>2</p>	<p>Ignore reference to Sn as a catalyst with the acid                      Allow H<sub>2</sub> (Ni / Pt) but penalise wrong metal                      But NOT NaBH<sub>4</sub> LiAlH<sub>4</sub> Na / C<sub>2</sub>H<sub>5</sub>OH</p> <p>12[H] and 4H<sub>2</sub>O without correct molecular formula scores                      1 out of 2                      Allow ..... + 6H<sub>2</sub> if H<sub>2</sub> / Ni used</p> <p>Allow –CONH– or –COHN– or –C<sub>6</sub>H<sub>4</sub>–</p> <p>Mark two halves separately : lose 1 each for</p> <ul style="list-style-type: none"> <li>• error in diamine part</li> <li>• error in diacid part</li> <li>• error in peptide link</li> <li>• missing trailing bonds at one or both ends</li> <li>• either or both of H or OH on ends</li> </ul> <p>Ignore <i>n</i></p>
7(b)	<p>H<sub>2</sub> (Ni / Pt) but penalise wrong metal                      CH<sub>2</sub>                      In benzene 120°                      In cyclohexane 109° 28' or 109½°                      If only one angle stated without correct qualification, no mark awarded</p>	<p>1</p> <p>1</p> <p>1</p> <p>1</p>	<p>NOT Sn / HCl, NaBH<sub>4</sub> etc.</p> <p>Allow 108° - 110°</p>

7(c)(i)	<p>Nucleophilic addition</p> <p>M2</p> <p>M1 <math>\text{H}^-</math></p> <p>M4 for lp, arrow and <math>\text{H}^+</math></p> <p>M3</p>	<p>1</p> <p>4</p>	<ul style="list-style-type: none"> <li>• M2 not allowed independent of M1, but allow M1 for correct attack on <math>\text{C}^+</math></li> <li>• + rather than <math>\delta^+</math> on <math>\text{C}=\text{O}</math> loses M2</li> <li>• M3 is for correct structure including minus sign but lone pair is part of M4</li> <li>• Allow <math>\text{C}_2\text{H}_5</math></li> <li>• M1 and M4 include lp and curly arrow</li> <li>• Allow M4 arrow to <u>H</u> in <math>\text{H}_2\text{O}</math> (ignore further arrows)</li> </ul>
7(c)(ii)	<p>M1 Planar <math>\text{C}=\text{O}</math> (bond/group)</p> <p>M2 Attack (equally likely) from either side</p> <p>M3 (about product): Racemic mixture formed <b>OR</b> 50:50 mixture or each enantiomer equally likely</p>	<p>1</p> <p>1</p> <p>1</p>	<p>Not just planar molecule</p> <p>Not just planar bond without reference to carbonyl</p>

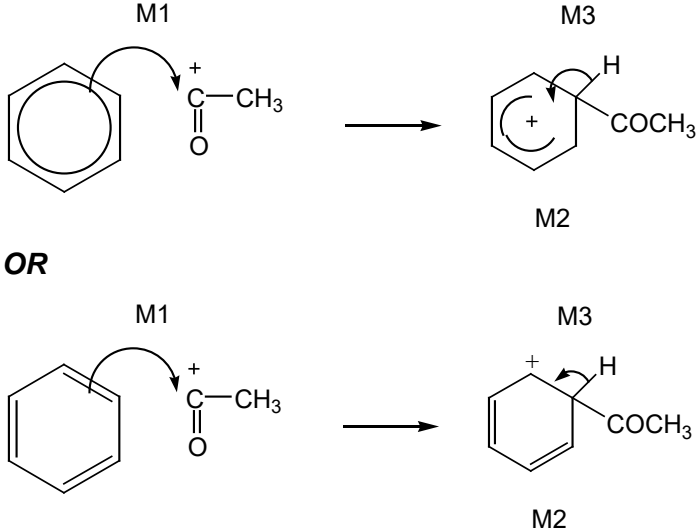

8(a)(ii)	<p>Electrophilic substitution</p> <p>M1</p>  <p>OR</p> <p>M1</p> <p>M2</p> <p>M3</p>	1  3	<ul style="list-style-type: none"> <li>• M1 arrow from within hexagon to C or to + on C</li> <li>• + must be on C of CH<sub>3</sub>CO in mechanism</li> <li>• + in intermediate not too close to C1</li> <li>• Gap in horseshoe must be centred approximately around C1</li> <li>• M3 arrow into hexagon unless Kekule</li> <li>• Allow M3 arrow independent of M2 structure, ie + on H in intermediate loses M2 not M3</li> <li>• Ignore base removing H for M3</li> </ul>
8(b)	<p>Electron <u>pair donor</u> or lone <u>pair donor</u></p> $\text{H}_3\text{C}-\overset{\text{O}}{\parallel}{\text{C}}-\text{O}-\overset{\text{O}}{\parallel}{\text{C}}-\text{CH}_3$ <p>(acid) anhydride</p>	1  1  1	<p>Allow donator</p> <p>Allow lone pair used in description of (dative) bond formation</p> <p>Allow (CH<sub>3</sub>CO)<sub>2</sub>O</p> <p>Allow ethanoic anhydride but not any other anhydride</p>



### **General principles applied to marking CHEM4 papers by CMI+ (January 2013)**

It is important to note that the guidance given here is generic and specific variations may be made at individual standardising meetings in the context of particular questions and papers.

Basic principles

- **Examiners should note that throughout the mark scheme, items that are underlined are required information to gain credit.**
- **Occasionally an answer involves incorrect chemistry and the mark scheme records CE = 0, which means a chemical error has occurred and no credit is given for that section of the clip or for the whole clip.**
- 

#### **A. The “List principle” and the use of “ignore” in the mark scheme**

If a question requires **one** answer and a student gives two answers, no mark is scored if one answer is correct and one answer is incorrect. There is no penalty if both answers are correct.

N.B. Certain answers are designated in the mark scheme as those which the examiner should “Ignore”. These answers are not counted as part of the list and should be ignored and will not be penalised.

#### **B. Incorrect case for element symbol**

The use of an incorrect case for the symbol of an element should be penalised **once only** within a clip. For example, penalise the use of “h” for hydrogen, “CL” for chlorine or “br” for bromine.

#### **C. Spelling**

In general

- The names of chemical compounds and functional groups **must be spelled correctly** to gain credit.
- Phonetic spelling may be acceptable for some chemical terminology.

N.B. Some terms may be required to be spelled correctly or an idea needs to be articulated with clarity, as part of the “Quality of Language” (**QoL**) marking. These will be identified in the mark scheme and marks are awarded only if the QoL criterion is satisfied.

#### D. Equations

In general

- Equations **must** be balanced.
- When an equation is worth two marks, one of the marks in the mark scheme will be allocated to one or more of the reactants or products. This is independent of the equation balancing.
- State symbols are generally ignored, unless specifically required in the mark scheme.

#### E. Reagents

The command word “Identify”, allows the student to choose to use **either** the name or the formula of a reagent in their answer. In some circumstances, the list principle may apply when both the name and the formula are used. Specific details will be given in mark schemes.

The guiding principle is that a reagent is a chemical which can be taken out of a bottle or container. Failure to identify complete reagents **will be penalised**, but follow-on marks (e.g. for a subsequent equation or observation) can be scored from an incorrect attempt (possibly an incomplete reagent) at the correct reagent. Specific details will be given in mark schemes.

For example, **no credit** would be given for

- the cyanide ion or  $\text{CN}^-$  when the reagent should be potassium cyanide or KCN;
- the hydroxide ion or  $\text{OH}^-$  when the reagent should be sodium hydroxide or NaOH;
- the  $\text{Ag}(\text{NH}_3)_2^+$  ion when the reagent should be Tollens' reagent (or ammoniacal silver nitrate). In this example, no credit is given for the ion, but credit could be given for a correct observation following on from the use of the ion. Specific details will be given in mark schemes.

In the event that a student provides, for example, **both** KCN and cyanide ion, it would be usual to ignore the reference to the cyanide ion (because this is not contradictory) and credit the KCN. Specific details will be given in mark schemes.

#### F. Oxidation states

In general, the sign for an oxidation state will be assumed to be positive unless specifically shown to be negative.

### G. Marking calculations

In general

- A correct answer alone will score **full marks** unless the necessity to show working is specifically required in the question.
- An arithmetic error may result in a one mark penalty if further working is correct.
- A chemical error will usually result in a two mark penalty.

### H. Organic reaction mechanisms

Curly arrows should originate either from a lone pair of electrons or from a bond.

**The following representations should not gain credit and will be penalised each time** within a clip.

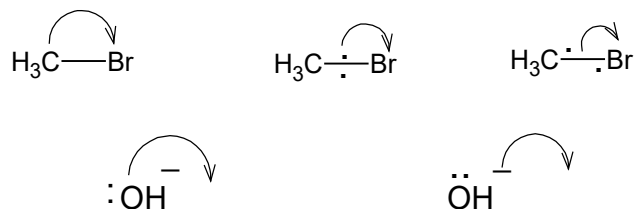

For example, the following would score zero marks

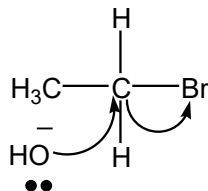

When the curly arrow is showing the formation of a bond to an atom, the arrow can go directly to the relevant atom, alongside the relevant atom or **more than half-way** towards the relevant atom.

In free-radical substitution

- The absence of a radical dot should be penalised **once only** within a clip.
- The use of double-headed arrows or the incorrect use of half-headed arrows in free-radical mechanisms should be penalised **once only** within a clip

In mass spectrometry fragmentation equations, the absence of a radical dot on the molecular ion and on the free-radical fragment would be considered to be two independent errors and both would be penalised if they occurred within the same clip.

## I. Organic structures

In general

- Displayed formulae must show all of the bonds and all of the atoms in the molecule, but need not show correct bond angles.
  - Bonds should be drawn correctly between the relevant atoms. This principle applies in all cases where the attached functional group contains a carbon atom, e.g nitrile, carboxylic acid, aldehyde and acid chloride. The carbon-carbon bond should be clearly shown. Wrongly bonded atoms will be penalised **on every occasion**. (see the examples below)
  - The same principle should also be applied to the structure of alcohols. For example, if students show the alcohol functional group as C – HO, they should be penalised **on every occasion**.
  - Latitude should be given to the representation of C – C bonds in alkyl groups, given that CH<sub>3</sub>– is considered to be interchangeable with H<sub>3</sub>C– even though the latter would be preferred.
  - Similar latitude should be given to the representation of amines where NH<sub>2</sub>– C will be allowed, although H<sub>2</sub>N– C would be preferred.
  - Poor presentation of vertical C – CH<sub>3</sub> bonds or vertical C – NH<sub>2</sub> bonds should **not** be penalised. For other functional groups, such as – OH and – CN, the limit of tolerance is the half-way position between the vertical bond and the relevant atoms in the attached group.
- By way of illustration, the following would apply.

<b>allowed</b>	<b>allowed</b>	not allowed	not allowed	not allowed
<b>allowed</b>	<b>allowed</b>	<b>allowed</b>	<b>allowed</b>	not allowed

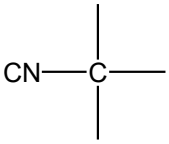
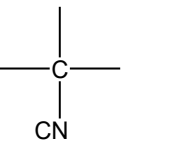
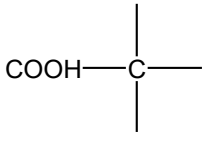
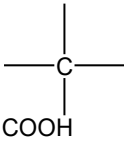
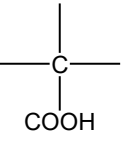
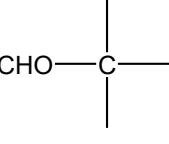
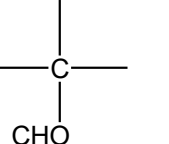
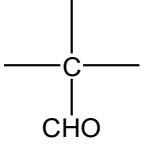
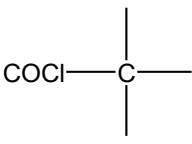
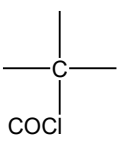
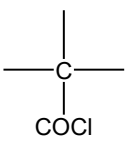
					
not allowed	not allowed	not allowed	not allowed	not allowed	
					
not allowed	not allowed	not allowed	not allowed	not allowed	not allowed

- In most cases, the use of “sticks” to represent C – H bonds in a structure should **not** be penalised. The exceptions will include structures in mechanisms when the C – H bond is essential (e.g. elimination reactions in haloalkanes) and when a displayed formula is required.
- Some examples are given here of **structures** for specific compounds that should **not** gain credit

CH<sub>3</sub>COH      for      ethanal

CH<sub>3</sub>CH<sub>2</sub>HO      for      ethanol

OHCH<sub>2</sub>CH<sub>3</sub>      for      ethanol

C<sub>2</sub>H<sub>6</sub>O      for      ethanol

CH<sub>2</sub>CH<sub>2</sub>      for      ethene

CH<sub>2</sub>.CH<sub>2</sub>      for      ethene

CH<sub>2</sub>:CH<sub>2</sub>      for      ethane

N.B. Exceptions may be made in the context of balancing equations

- Each of the following **should gain credit** as alternatives to correct representations of the structures.

CH<sub>2</sub> = CH<sub>2</sub>      for      ethene, H<sub>2</sub>C=CH<sub>2</sub>

CH<sub>3</sub>CHOHCH<sub>3</sub>      for      propan-2-ol, CH<sub>3</sub>CH(OH)CH<sub>3</sub>

### J. Organic names

As a general principle, non-IUPAC names or incorrect spelling or incomplete names should **not** gain credit. Some illustrations are given here.

but-2-ol	should be <b>butan-2-ol</b>
2-hydroxybutane	should be <b>butan-2-ol</b>
butane-2-ol	should be <b>butan-2-ol</b>
2-butanol	should be <b>butan-2-ol</b>
2-methopropan-2-ol	should be <b>2-methylpropan-2-ol</b>
2-methylbutan-3-ol	should be <b>3-methylbutan-2-ol</b>
3-methylpentan	should be <b>3-methylpentane</b>
3-mythylpentane	should be <b>3-methylpentane</b>
3-methypentane	should be <b>3-methylpentane</b>
propanitrile	should be <b>propanenitrile</b>
aminethane	should be <b>ethylamine</b> (although aminoethane can gain credit)
2-methyl-3-bromobutane	should be <b>2-bromo-3-methylbutane</b>
3-bromo-2-methylbutane	should be <b>2-bromo-3-methylbutane</b>
3-methyl-2-bromobutane	should be <b>2-bromo-3-methylbutane</b>
2-methylbut-3-ene	should be <b>3-methylbut-1-ene</b>
difluorodichloromethane	should be <b>dichlorodifluoromethane</b>